

DAVID KEILIN'S RESPIRATORY CHAIN CONCEPT AND ITS CHEMIOSMOTIC CONSEQUENCES

Nobel Lecture, 8 December, 1978

by

PETER MITCHELL

Glynn Research Institute, Bodmin, Cornwall, U. K.

0. INTRODUCTION

It was obviously my hope that the chemiosmotic rationale of vectorial metabolism and biological energy transfer might one day come to be generally accepted, and I have done my best to argue in favour of that state of affairs for more than twenty years. But, it would have been much too presumptuous to have expected it to happen. Of course, I might have been wrong, and in any case, was it not the great Max Planck (1928, 1933) who remarked that a new scientific idea does not triumph by convincing its opponents, but rather because its opponents eventually die? The fact that what began as the chemiosmotic hypothesis has now been acclaimed as the chemiosmotic theory - at the physiological level, even if not at the biochemical level - has therefore aroused in me emotions of astonishment and delight in full and equal measure, which are all the more heartfelt because those who were formerly my most capable opponents are still in the prime of their scientific lives.

I shall presently explain the difference between the physiological and the biochemical levels at which the chemiosmotic theory has helped to promote useful experimental research. But let me first say that my immediate and deepest impulse is to celebrate the fruition of the creative work and benevolent influence of the late David Keilin, one of the greatest of biochemists and - to me, at least - the kindest of men, whose marvellously simple studies of the cytochrome system, in animals, plants and microorganisms (Keilin, 1925), led to the original fundamental idea of aerobic energy metabolism: the concept of the respiratory chain (Keilin, 1929; and see Nicholls, 1963; King, 1966). Perhaps the most fruitful (and surprising) outcome of the development of the notion of chemiosmotic reactions is the experimental stimulus and guidance it has provided in work designed to answer the following three elementary questions about respiratory chain systems and analogous photoredox chain systems: What is it? What does it do? How does it do it? The genius of David Keilin led to the revelation of the importance of these questions. In this lecture, I hope to show that, as a result of the painstaking work of many biochemists, we can now answer the first two in general principle, and that considerable progress is being made in answering the third.

Owing to the broad conceptual background, and the very wide range of practical application of the chemiosmotic theory, I have had to be rather

selective in choosing aspects to review. I have chosen to consider the evolution of the chemiosmotic theory from earlier fundamental biochemical and physicochemical concepts in three perspectives: 1, a middle-distance physiological-cum-biochemical perspective; 2, a longer physicochemical view; and 3, a biochemical close-up. These perspectives involve general considerations of biochemical theory and knowledge, and scope is not available to discuss experimental procedures on this occasion.

1. PHYSIOLOGICAL-CUM-BIOCHEMICAL PERSPECTIVE

A. Oxidative and Photosynthetic Phosphorylation

During the two decades between 1940 and 1960, the mechanism of oxidative phosphorylation (by which some 95% of the energy of aerobic organisms is obtained), and the basically similar mechanism of photosynthetic phosphorylation (by which much of the energy available from plant products is initially harvested from the sun) was recognised as one of the great unsolved problems of biochemistry. At the beginning of this period, the work of David Keilin (1925, 1929) on the cytochrome system, and work by Warburg, Wieland and others on the respiratory hydrogen carriers, had already led to the concept of the respiratory chain: a water-insoluble complex of redox carriers, operating serially between the reducing substrates or coenzymes and molecular oxygen (see Nicholls, 1963; King, 1966).

As indicated in Fig. 1, according to Keilin's chemically simple concept of

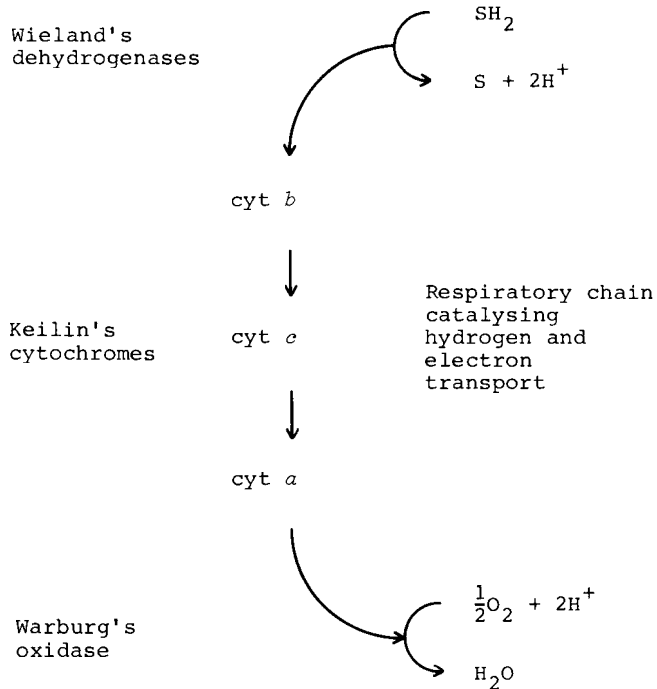

Fig. 1. David Keilin's chemically simple respiratory chain concept.

the respiratory chain, the respiratory-chain carriers (or their complexes of molecular dimensions) were involved chemically only in redox reactions. However, when, following the pioneer work of Kalckar (1937), Belitser & Tsybakova (1939), Ochoa (1940), Lipmann (1941, 1946), Friedkin & Lehninger (1948), and Arnon, Whatley & Allen (1954), attention was directed to the mechanism by which the redox process was coupled to the phosphorylation of ADP in respiratory and photoredox metabolism, it was natural for the metabolic enzymologists who were interested in this problem to use substrate-level phosphorylation as the biochemical model, and to assume that the mechanism of coupling between oxidation and phosphorylation in respiratory and photoredox chains would likewise be explained in terms of the classically scalar idiom of metabolic enzymology (see Slater, 1976).

In 1953, the general chemical coupling hypothesis, summarised in Fig. 2, was given formal expression in a historically important paper by Slater, which defined the reactions of the energy-rich intermediates at several coupling sites along the mitochondrial respiratory chain. Accordingly,

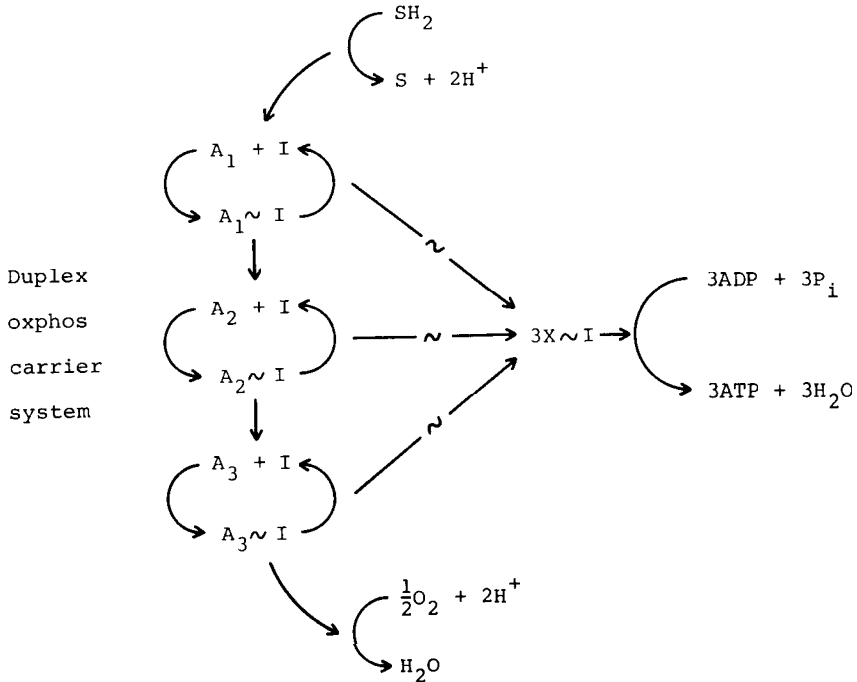

Fig. 2. Phosphorylating respiratory chain: Chemical coupling hypothesis. $\text{A} \sim \text{I}$ and $\text{X} \sim \text{I}$ represent hypothetical high-energy chemical intermediates; and the symbol \sim represents the so-called high-energy bond.

many expert metabolic enzymologists made it their prime objective to identify the energy-rich intermediates or other coupling factors supposed to be responsible for coupling oxidoreduction to phosphorylation in redox chain systems (Slater, 1953; Boyer et al., 1954; Chance & Williams, 1956;

Slater, 1958; Lehninger, 1959; Slater & Hulsmann, 1959; Chance, 1961; Racker, 1961; Lehninger & Wadkins, 1962; Williams, 1962; Boyer, 1963; Green et al., 1963; Hatefi, 1963; Ernster & Lee, 1964; Lardy et al., 1964; Griffiths, 1965; Racker, 1965; Sanadi, 1965; Slater, 1966; Chance et al., 1967). This development caused Keilin's chemically-simple concept of the respiratory chain to be almost universally rejected in favour of a chemically duplex concept according to which respiratory chain components participated directly, not only in the known redox changes, but also in other chemical changes involving the energy-rich intermediates - just as the phosphorylating glyceraldehyde-3-phosphate dehydrogenase is involved in both oxidative and phosphorylative reactions.

By the end of the two and a half decades between 1940 and 1965, the field of oxidative phosphorylation was littered with the smouldering conceptual remains of numerous exploded energy-rich chemical intermediates; the remarkable uncoupling action of 2,4-dinitrophenate and of other chemically unrelated reagents, and of physical membrane-lytic treatments, remained obscure; and the process of hypothesis-building, needed to keep faith with the chemical-coupling notion, reached such fantastic proportions as to be hardly intelligible to those outside the field (see Mitchell, 1961 c, 1966, 1967 a). Nevertheless, the quest for the energy-rich intermediates continued through the nineteesixties and persisted into the nineteenseventies with only a minor broadening of the conception of the type of coupling mechanism favoured by many of the metabolic enzymologists (Painter & Hunter, 1970; Storey, 1970, 1971; Slater, 1971, 1974, 1975; Chance, 1972, 1974; Hatefi & Hanstein, 1972; Wang, 1972; Cross & Boyer, 1973; Boyer et al., 1973, 1977; Ernster et al., 1973, 1974; Green, 1974; Weiner & Lardy, 1974; Griffiths et al., 1977; Nordenbrand et al., 1977). This conceptual broadening, which began to occur during the early nineteesixties, stemmed from ingenious suggestions by Boyer, Chance, Ernster, Green, Slater, Williams and others (see Boyer, 1965; Slater, 1971, 1974; Ernster et al., 1973). As indicated by Fig. 3, they assumed that coupling may be achieved through a direct conformational or other non-osmotic physical or chemical interaction - that might, for example, involve protons as a localised anhydrous chemical intermediate (Williams, 1962, 1970; and see Ernster, 1977 a; Mitchell, 1977 a), or might involve electrical interaction (Green, 1974) - between the redox carrier proteins and certain catalytic components associated with ATP synthesis in the supposedly duplex respiratory chain system, often described as the "phosphorylating respiratory chain".

Soon after 1950, it began to be recognised that the water-insoluble property of preparations of respiratory chain and photoredox chain complexes was related to the circumstance that, in their native state, these complexes were part of the lipid membrane system of bacteria, mitochondria and chloroplasts. But, such was the lack of liaison between the students of transport and the students of metabolism, that the significance of this fact for the field of oxidative and photosynthetic phosphorylation was

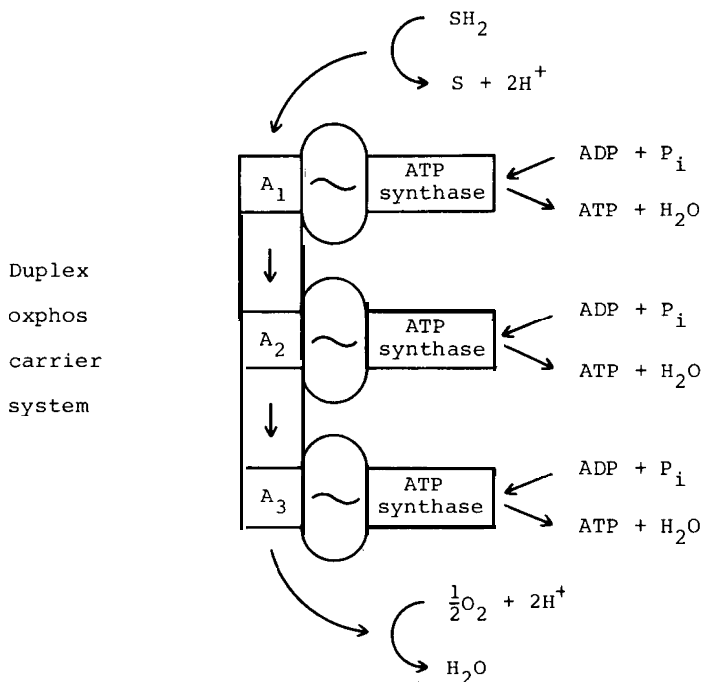

Fig. 3. Phosphorylating respiratory chain: Local interaction coupling hypothesis. The symbol \sim represents a localised "high-energy" chemical intermediary or physical state.

not appreciated, despite suggestive clues provided, for example, by Lundegardh (1945), Robertson & Wilkins (1948), Using (1949), Davies & Ogston (1950), Conway (1951) and me (Mitchell, 1954). These clues suggested that some osmotic type of protonic coupling mechanism might be feasible (see Robertson, 1960, 1968; Lehninger, 1962). It was in this context that I began to take an active outsider's interest in this fundamental problem of energy metabolism in the nineteenfifties (and occasionally talked to David Keilin about it), while I was mainly engaged in trying to develop general principles of coupling between metabolism and transport, by means of the biochemical concepts of chemiosmotic group-translocation reactions and vectorial metabolism (Mitchell, 1954, 1956, 1957, 1959, 1961 a, b; Mitchell & Moyle, 1956, 1958a, b). I shall define these concepts more fully later. For the moment, suffice it to remark that it was these essentially biochemical concepts (Mitchell, 1961 a, b, 1962, 1963, 1967 b, c, 1970a, b, 1972b, 1973 a, b, c, 1977c), and not my relatively subsidiary interest in energy metabolism, that led me to formulate the coupling hypothesis, summarised in Fig. 4, which came to be known as the chemiosmotic hypothesis. As it happened, the main protonmotive ATPase principle of this hypothesis was first outlined at an international meeting held in Stockholm in 1960 (Mitchell, 1961 b). My motivation was simply a strategic conjectural one. There was a chance worth exploring that the chemiosmotic rationale might provide a generally acceptable conceptual framework in the field of membrane bioenergetics and oxidative phosphorylation, and that, if so, it

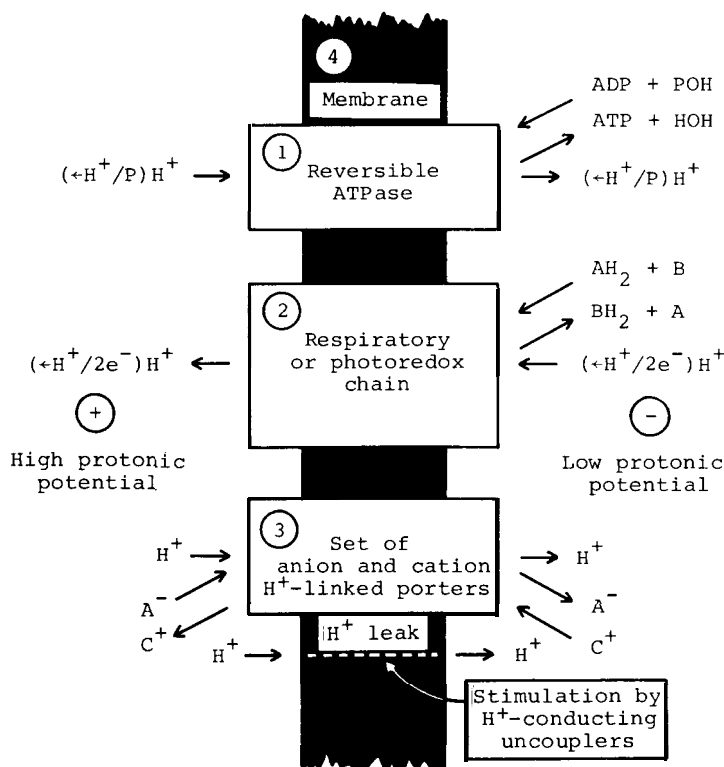

Fig. 4. Chemiosmotic hypothesis: Physiological level.

might encourage more adventurous and successful interdisciplinary research by improving communication and acting as a kind of navigational aid (see Mitchell, 1961 c, 1963, 1976a, 1977 b).

There are two conceptual levels at which the chemiosmotic rationale has helped to promote useful experimental research.

The level represented by Fig. 4 is essentially physiological. It aims to answer the question: what does it do? At this conceptual level one makes use of the general principle of coupling by proticity, the protonic analogue of electricity. Separate protonmotive redox (or photoredox) and reversible protonmotive ATPase complexes are conceived as being plugged through a topologically closed insulating membrane between two proton-conducting aqueous media at different protonic potential. Thus, coupling may occur, not by direct chemical or physical contact between the redox and reversible ATPase systems, but by the flow of proticity around an aqueous circuit connecting them. I use the word proticity for the force and flow of the proton current by analogy with the word electricity, which describes the force and flow of an electron current (Mitchell, 1972 a, 1976 a). However, the total protonic potential difference $\Delta\phi$ has both electric ($\Delta\psi$) and chemical activity (ΔpH) components, according to the equation:

$$\Delta\phi = \Delta\psi - Z\Delta\text{pH} \quad (1)$$

where Z is the conventional factor $2.303 RT/F$, which is near 60 at 25° , when the potentials are expressed in mV (Mitchell, 1961 c, 1966, 1968).

To promote experimental research programmes designed to test, and if possible to falsify, the physiological-level chemiosmotic coupling concept, it was explicitly and unambiguously formulated (Mitchell, 1961 c, 1966) in terms of the following four fundamental postulates, corresponding to the four structural and functional systems represented in Fig. 4:

1. The ATP synthase is a chemiosmotic membrane-located reversible ATPase, having characteristic $\leftarrow H^+/P$ stoichiometry.
2. Respiratory and photoredox chains are chemiosmotic membrane-located systems, having characteristic $\leftarrow H^+/2e^-$ stoichiometry, and having the same polarity of proton translocation across the membrane for normal forward redox activity as the ATPase has for ATP hydrolysis.
3. There are proton-linked (or hydroxyl-ion-linked) solute porter systems for osmotic stabilisation and metabolite transport.
4. Systems 1 to 3 are plugged through a topologically closed insulating membrane, called the coupling membrane, that has a nonaqueous osmotic barrier phase of low permeability to solutes in general and to hydrogen ions and hydroxyl ions in particular. This is the cristae membrane of mitochondria, the thylakoid membrane of chloroplasts, and the plasma membrane of bacteria.

These postulates were almost entirely hypothetical and experimentally unexplored when they were given as the basis of the chemiosmotic hypothesis in 1961. My original guesses for the $\leftarrow H^+/P$ and $\leftarrow H^+/O$ stoichiometries, and for the protonmotive polarity across the membrane (Mitchell, 1961c), required revision in the light of early experiments (Mitchell, 1963; Mitchell & Moyle, 1965, 1967, 1968). Fig. 5 represents the correct polarities, and what I think are probably the correct protonmotive stoichiometries: A, for the mitochondrial oxidative phosphorylation system (not including the porters); and B, for the chloroplast non-cyclic photophosphorylation system. No change of fundamental principle was, however, involved; and the postulates, represented by Figs. 4 and 5, have now survived seventeen years of intensive scrutiny by many research workers, using a great variety of experimental methods in many different research laboratories, including my own (see: Racker, 1976; Papa, 1976; Boyer et al., 1977; Ernster, 1977b; Bendall, 1977; Harold, 1977a; Jagendorf, 1977; Kozlov & Skulachev, 1977; Skulachev, 1977; Witt, 1977; Dutton et al., eds, 1978; Hall et al., eds. 1978; Hinkle & McCarty, 1978; Junge et al., 1979a,b; Mitchell, 1976a, 1977a, 1979). The progress of research on oxidative and photosynthetic phosphorylation became much faster as soon as the molecular complexes represented by each of the four postulates began to be treated as biochemically separate systems (Fig. 4) that could best be studied individually - as in the laboratories of Jagendorf (1967), Racker (1967), Witt (1967), Chappell (1968) and Skulachev (1970) - instead of being mixed up in the so-called "phosphorylating respiratory chain" or its photosynthetic analogue.

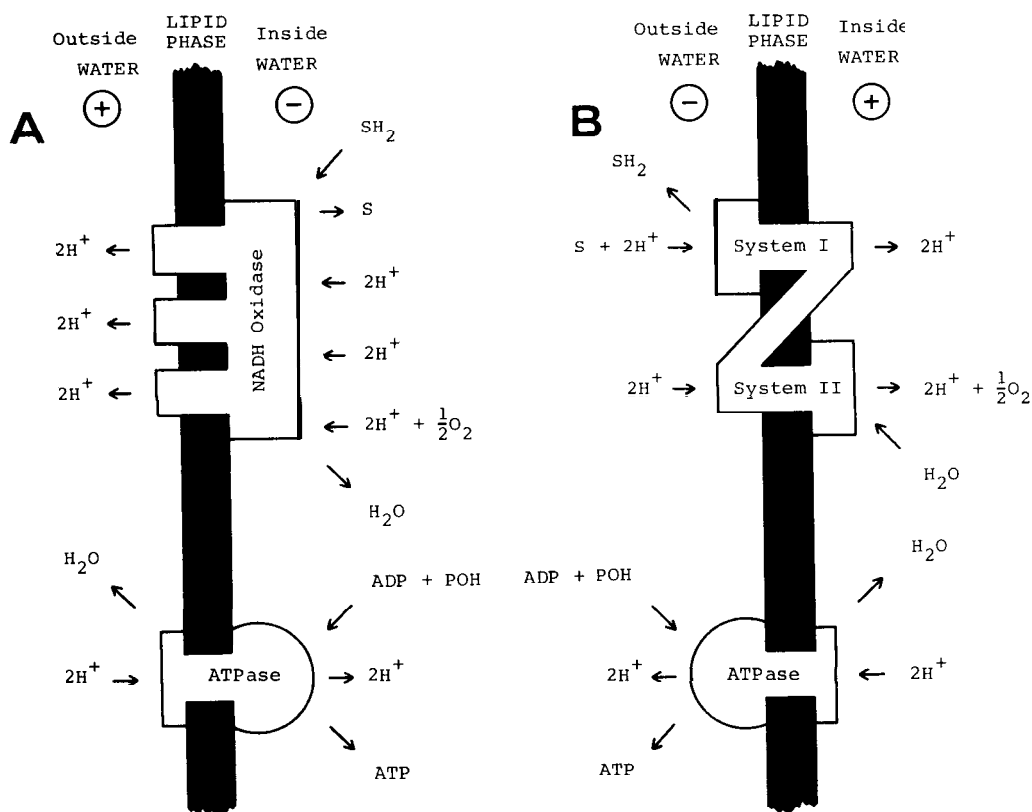

Fig. 5. Oxidative phosphorylation (A); and Photosynthetic phosphorylation (B) coupled by proticity (after Mitchell, 1967a).

The physiological-level concept of chemiosmotic coupling includes, not only the general principle of transformation of redox energy to phosphorylation energy, but also the principle of transmission of power from the redox complexes plugged through the membrane at one point to the reversible ATPase and other proticity-consuming complexes plugged through the membrane anywhere else (Mitchell, 1976a, 1977c). This circumstance has helped to place the mechanism of oxidative and photosynthetic phosphorylation in perspective in the broader field of membrane bioenergetics and general physiology - with particularly striking results for our understanding of microbial membrane transport and related processes (see Harnilton & Haddock, eds, 1977; Harold, 1977a,b; Rosen & Kashket, 1978).

The four postulates, representing the four systems with characteristic properties, are now widely regarded as experimentally established facts. Thus, we appear to have answered the question: What does it do? The

plug-through respiratory chain and photoredox chain complexes generate proticity across the coupling membrane, energising the aqueous conductors on either side, so that power can be drawn off by other plug-through complexes, such as the reversible protonmotive ATPase. However, this acceptance of the chemiosmotic coupling concept at the physiological level is without prejudice to the possible biochemical mechanisms of the protonmotive ATPase and redox complexes, and fixes their relative but not their absolute protonmotive stoichiometries (Boyer et al., 1977; Ernster, 1977b).

The other conceptual level at which the chemiosmotic rationale has helped to promote useful experimental research is essentially biochemical. It concerns the functional stoichiometries, the molecular topologies and the molecular mechanisms of the protonmotive ATPase, the redox (or photoredox) complexes, and the porter complexes of postulates 1, 2, and 3.

In my opinion, the biochemical content and value of the chemiosmotic rationale depended from the outset on the feasibility of protonmotive chemiosmotic reaction mechanisms of the direct group-translocation type, exemplified by the redox loop and the hydrodehydration loop (Mitchell, 1966, 1967a,b,c), which are relatively orthodox biochemically, and require little more than the addition of a spatial dimension to Lipmann's concept of chemical group potential (Lipmann, 1941, 1946, 1960). Had this not been so, I would not have thought it worth fostering the chemiosmotic hypothesis, as I shall now proceed to explain.

B. The Coupling of Metabolism and Transport: Vectorial Metabolism

The photograph in Fig. 6 was taken in a tiny research room in the basement of the Department of Biochemistry in Cambridge, England, in 1942 or 1943, when I first began to do biophysical and biochemical research. It shows Jim Danielli, Joan Keilin (David Keilin's daughter), Mrs. Danielli (who was acting as Jim Danielli's technician) and me. Jim Danielli, who is seen there operating a surface balance on a Langmuir trough, was my research supervisor. He exposed me to the techniques and concepts of the membranologists and students of transport, while the general outlook of the Cambridge Biochemistry Department, in which we were working, was that of classical homogeneous solution metabolic enzymology. Intermediately was the position of David Keilin, at the Molteno Institute, with his studies of the insoluble cytochrome system and associated components, making up the respiratory chain.

I could not but be impressed by the great divergence of outlook, and even mutual antagonism, between the students of membranes and transport on the one hand, and the students of metabolic enzymology on the other hand - and I soon determined to try to understand both points of view in the hope that they might be brought together.

About seven years elapsed before I had accidentally become a microbi-



Fig. 6. Research at the bench in 1942 or 1943. Department of Biochemistry, Cambridge, England. From left to right: Joan Keilin, Jim Danielli, Peter Mitchell, Mary Danielli.

ologist and was involved: first, in studies of a functional aspect of the plasma membrane of bacteria, which I called the osmotic barrier (Mitchell, 1949); and soon after, in studies of the specific uptake and exchange of inorganic phosphate and arsenate through a catalytic system present in the osmotic barrier of staphylococci (Mitchell, 1954; and see Mitchell & Moyle, 1956). This enabled me to give my full attention to the functional and

conceptual relationships between chemical and osmotic reactions. The remarkably high specificity of the phosphate translocation reaction in staphylococci, its susceptibility to specific inhibitors including SH-reactors, its high entropy of activation, which indicated a large conformational change in the translocator system, and the tight coupling of phosphate translocation against arsenate translocation that I observed - as in the phenomenon of exchange-diffusion previously described by Using (1947) - indicated how closely osmotic translocation reactions could resemble (or could be functionally related to) enzyme-catalysed group-transfer reactions (Mitchell, 1956, 1957, 1959). Further, my observation with Jennifer Moyle, that the plasma membrane material isolated from staphylococci contained the cytochrome system and associated enzyme activities (Mitchell, 1956;

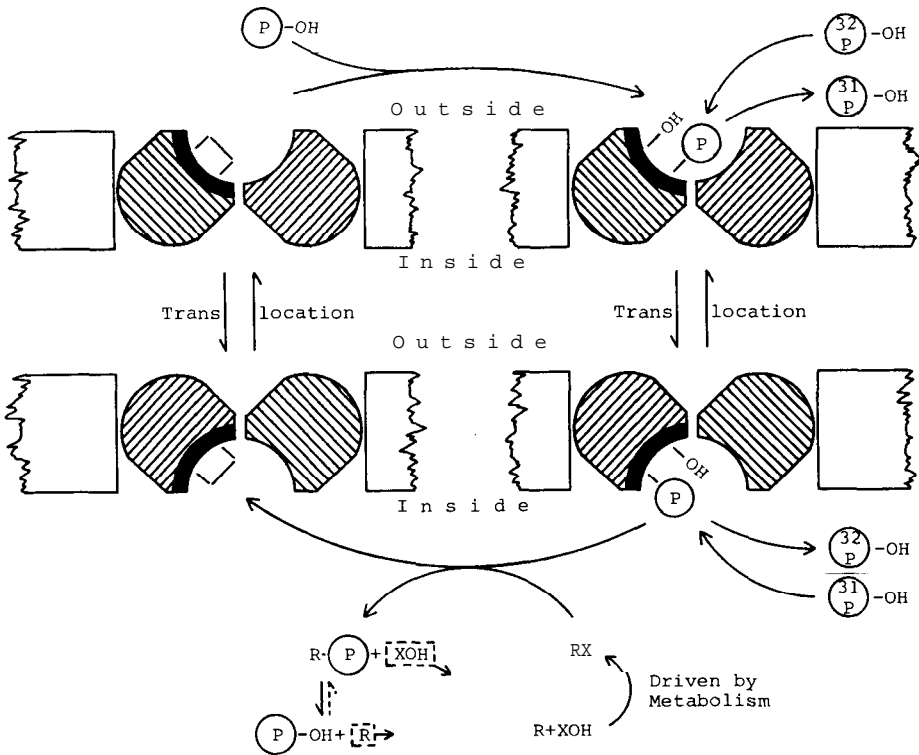

Fig. 7. Hypothetical enzyme system for phosphoryl group translocation (from Mitchell, 1957).

Mitchell & Moyle, 1956), suggested that one should generalise Lundegardh's idea of vectorial electron translocation through the cytochrome system (Lundegardh, 1945). Thus, from this work, and from related observations and ideas, notably of Lipmann (1941), Robertson & Wilkins

(1948), Rosenberg (1948), Pauling (1950), Davies & Ogston (1950) and Conway (1951), I surmised that certain of the group-transfer reactions, catalysed by the enzyme and catalytic carrier systems in the bacterial plasma membrane, might actually be vectorial group-translocation reactions, because of the anisotropic topological arrangement and specific conformational mobility of the catalytic systems. These, then were the circumstances that led me to remark at a symposium in 1953: ". . . in complex biochemical systems, such as those carrying out oxidative phosphorylation (e.g. Slater & Cleland, 1953) the osmotic and enzymic specificities appear to be equally important and may be practically synonymous" (Mitchell, 1954).

The general idea that I had in mind in the mid-nineteenfifties, illustrated by the hypothetical system for phosphoryl translocation reproduced in Fig. 7, was that of substrate-specific conformationally mobile enzyme and catalytic carrier systems catalysing the translocation, not only of solutes, but also of chemical groups. Thus, by the spatial extension of the group-potential concept of Lipmann (1941), transport could be conceived biochemically as being directly driven by the real vectorial forces of metabolic group-potential gradients. Hence the concepts of what I called chemiosmotic reactions and vectorial metabolism - bringing together transport and metabolism into one and the same chemiosmotic molecular-level biochemical process catalysed by group-conducting or conformationally mobile group-translocating enzyme systems (Mitchell, 1957, 1959). This led directly to the explicit concept of energetic coupling through enzyme-catalysed group translocation, as described in two papers by Jennifer Moyle and me in 1958. Fig. 8, from this work, represents a hypothetical example in which phosphoryl is conducted from ATP on the left to a substrate S on the right (Mitchell & Moyle, 1958a,b).

Mechanistically, the group translocation or conduction concept was a development of the idea, put forward by Pauling in 1950, that enzymic catalysis depends on tight binding of the transition-state complex rather than of reactants and resultants. As we pointed out (Mitchell & Moyle, 1958b), Pauling's idea required only a small adjustment to adapt it to the notion that the active centre regions of certain enzymes (and of certain catalytic carriers, such as cytochromes) may be conceived, not simply as specific group-binding centres, which would tend to lock in the transition state, but rather as specific group-conducting devices that facilitate the passage of chemical groups through a region of the catalytic complex between separate domains that specifically interact with the group-donor and group-acceptor species.

It was, of course, realised that the chemicomotive effect of group translocation - or group conduction, as I now prefer to call it - would not be manifested unless the enzyme or catalytic carrier molecules were inhomogeneously organised in space according to either of two main topological principles. According to one topological principle, the organisation could be at the macroscopic level in a membrane, thus giving rise to macroscopic

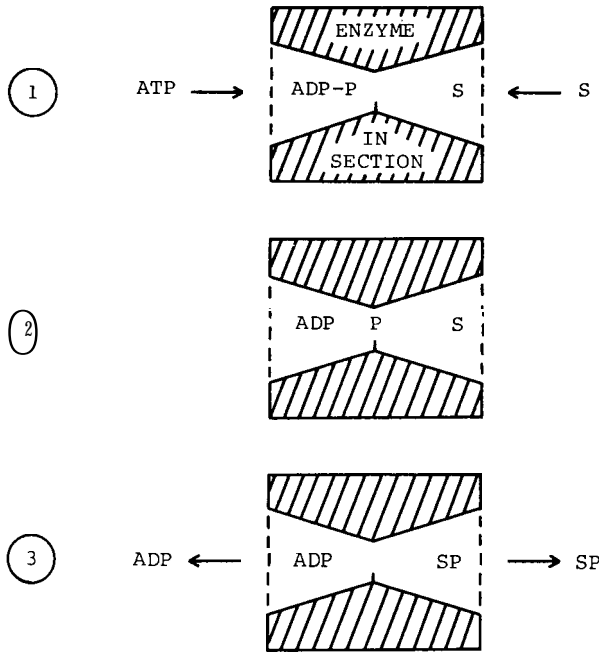

Fig. 8. Enzyme-catalysed group translocation illustrated by hypothetical phosphoryl translocation from ATP to a substrate S (from Mitchell & Moyle, 1958b).

chemiosmotic processes of which we gave some permutations and combinations for a phosphokinase system by way of example, as shown in Table 1. The two aqueous phases are represented to right and left of the central line denoting the membrane containing the anisotropic phosphokinase; and, in each example, the chemical (group-transfer) reaction is represented as progressing downwards, while the osmotic (group-translocation) reaction is represented as progressing through the phosphokinase in the membrane. The table illustrates that the overall chemiosmotic process would depend as much on the osmotic translocational (or conformational) specificities as on the chemical specificities of the catalytic system. It is in this respect that the vectorial chemiosmotic system differs fundamentally from conventionally scalar chemical ones.

The second case in Table 1 is shown in diagram A of Fig. 9. It represents the macroscopic chemiosmotic group-conduction principle applied to the phosphorylative translocation of the substrate GH, which could be a sugar, as in the phosphoenol pyruvate phosphotransferase system discovered in bacteria by Kundig, Ghosh & Roseman in 1964.

Now, it was only a small, but nevertheless important, step from Table 1 to write heterolytic protonmotive ATPase reactions as shown in B and C of Fig. 9. My original proposal (Mitchell, 1961b,c) for the protonmotive ATPase, reproduced in Fig. 10, corresponds to the group-translocation system of Fig. 9 B.

According to the other topological principle for manifesting the chemiosmotic effect of group translocation, we suggested that the organisation

EXAMPLE	CHEMI-OSMOTIC PROCESS			GROUPS TRANSPORTED
	LEFT PHASE	PHOSPHOKINASE IN MEMBRANE	RIGHT PHASE	
1	ATP ADP		S SP	$\xrightarrow{P-}$
2	ATP ADP + SP		S SP	$\xleftarrow{S-}$
3	ATP + S ADP		SP	$\xrightarrow{S-}$ $\xrightarrow{P-}$
4	ATP		S ADP + SP	$\xrightarrow{ADP-}$ $\xrightarrow{P-}$
5	ADP		S + ATP SP	$\xleftarrow{ADP-}$
6	ATP SP		S ADP	$\xrightarrow{ADP-}$ $\xleftarrow{S-}$
7	ATP + S		ADP + SP	$\xrightarrow{ADP-}$ $\xrightarrow{P-}$ $\xrightarrow{S-}$

Table 1. Alternative translocation-specific chemiosmotic processes catalysed by a hypothetical phosphokinase in a membrane (from Mitchell & Moyle, 1958b).

could be at the microscopic level, by pairing and enclosure of a 'microscopic internal phase' between neighbouring catalytic units, thus giving rise to a chemical coupling effect. As illustrated in Fig. 11 A, we cited as possible examples the NADP-linked isocitrate dehydrogenase and the malic enzyme, which catalyse consecutive oxidation and decarboxylation reactions (with oxalosuccinate and oxaloacetate respectively as intermediates trapped in the microscopic internal phase). We pointed out that such pairing of catalytic units could be developed in three dimensions for branching or cycling reaction sequences in enzyme complexes (Mitchell &

PROTONMOTIVE ATPases

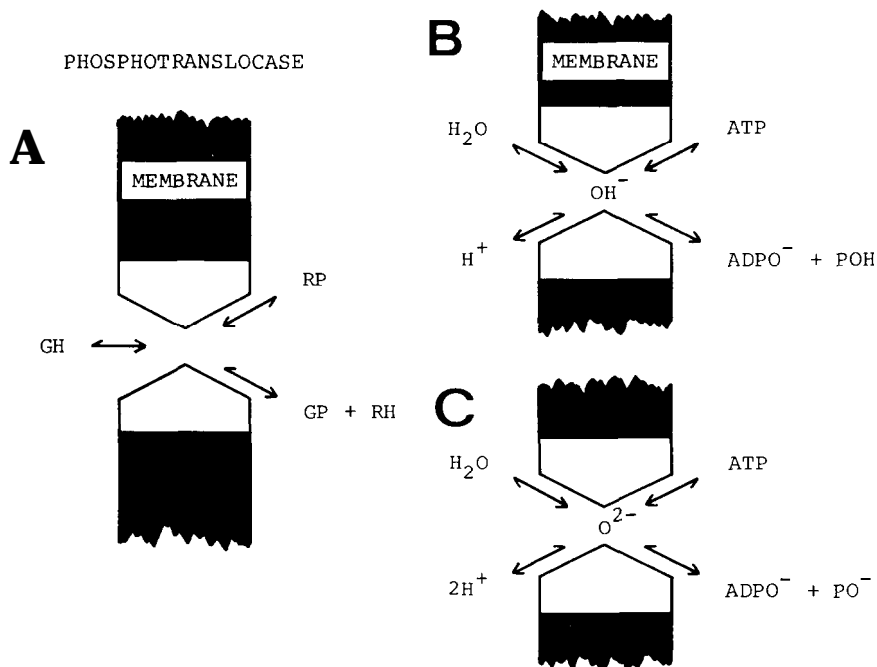

Fig. 9. Topologically macroscopic chemiosmotic group conduction: A, of group G, energised by phosphate transfer; B and C, of OH⁻ and O²⁻ respectively, energised by ATP hydrolysis.

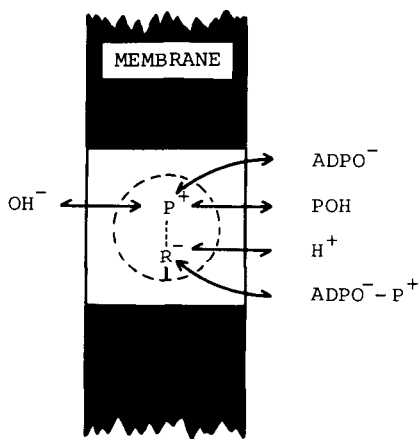

Fig. 10. Protonmotive ATPase translocating OH⁻ (from Mitchell, 1961c).

Moyle, 1958a,b). Diagrams B and C in Fig. 11 represent relevant hypothetical examples of the application of this microscopic coupling principle to redox (o/r) and hydrodehydration (h/d) complexes respectively. B represents consecutive hydrogen and electron transfer, via a flavoprotein (Fp) or ubiquinone (Q) and an ironsulphur protein (FeS) complex, as, perhaps, in NADH dehydrogenase; and C shows consecutive H₂O and O²⁻

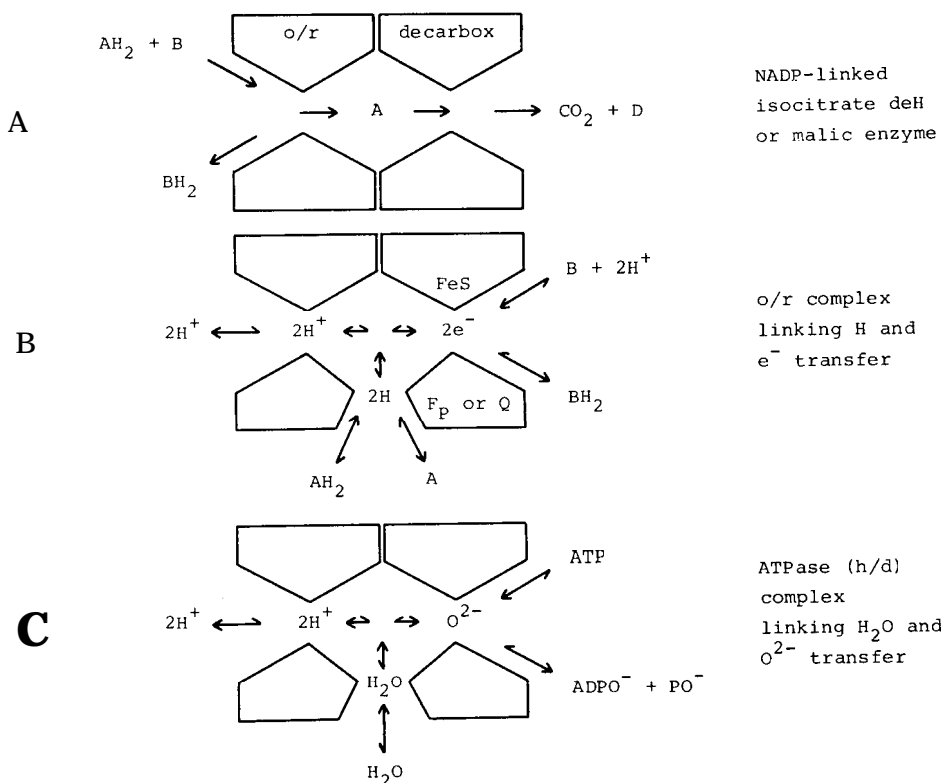

Fig. 11. Topologically microscopic chemiosmotic coupling systems: A, for oxidative decarboxylation; B, for successive H and e^- transfer; C, for successive H_2O and O^{2-} transfer (following Mitchell & Moyle, 1958a, b).

transfer, the latter via $(ADPO^- + PO^-)/ADPOP$ antiport in an ATPase complex.

The microscopic pairing and the macroscopic chemiosmotic principles of topological organisation have been developed together in chemiosmotic reaction systems. This is illustrated by Fig. 12, in which examples B and C of Fig. 11 have been plugged through a membrane to give a protonmotive redox loop complex and a protonmotive ATPase (hydrodehydration loop) complex respectively. Fig. 13 A and B represent the protonmotive redox loop in a more conventional nomenclature where X and Y are hydrogen and electron carrier respectively. It is, perhaps, more obvious from this cycling carrier style of representation that, in direct chemiosmotic mechanisms, the conformational movements or conduction processes of translocation overlap (in space-time) with the chemical processes of group transfer; and the chemiosmotic stoichiometry depends on the chemical properties, conformational articulations and/or conductive properties of the catalytic carriers, according to relatively conventional biochemical principles.

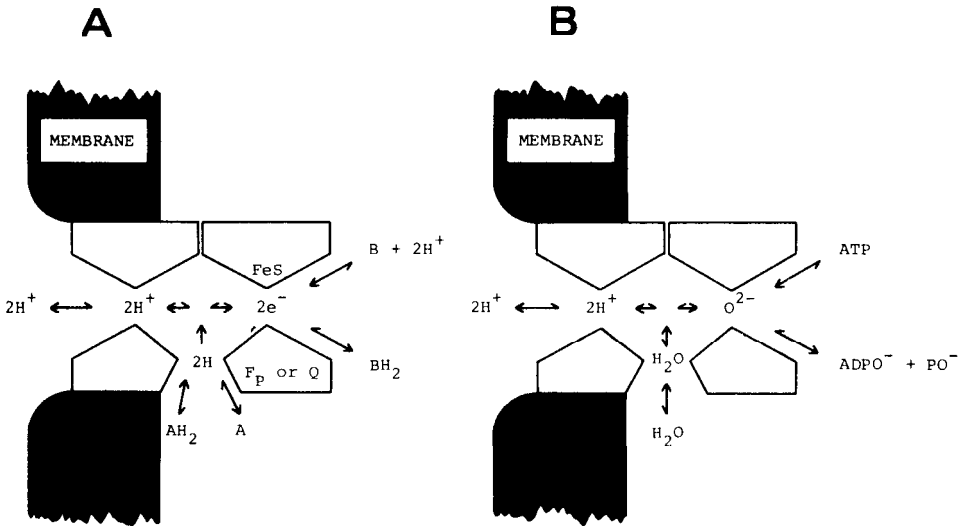

Fig. 12. Macroscopic and microscopic topological principles developed together in: A, proton-motive redox loop; B, protonmotive ATPase (hydrodehydration loop).

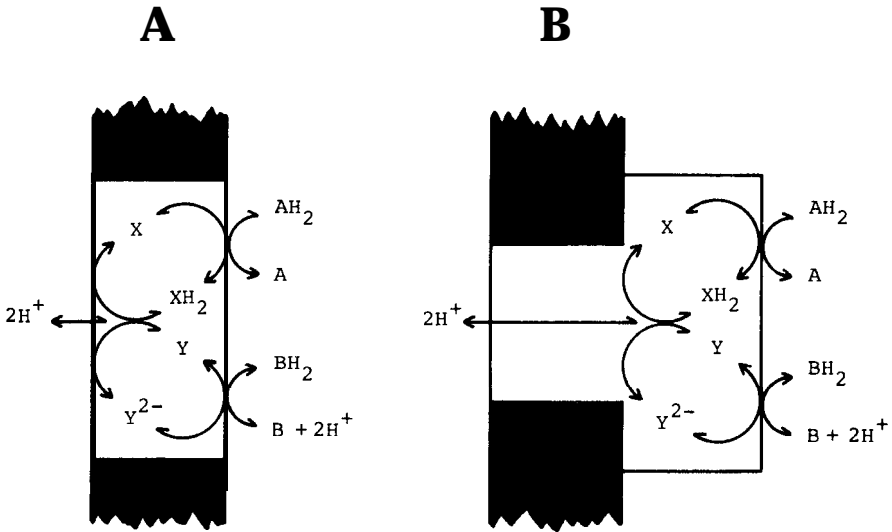

Fig. 13. Direct redox loop mechanism in cycling carrier idiom: A, plugged through the membrane; B, connected through a proton-conducting component (following Mitchell, 1966 and 1968).

C. The Protonmotive Respiratory Chain and Photoredox Chain: What is it? How does it do it?

Let us return to the theme of David Keilin's respiratory chain in the light of the essentially biochemical concept of direct group-translocating or group-conducting chemiosmotic mechanisms.

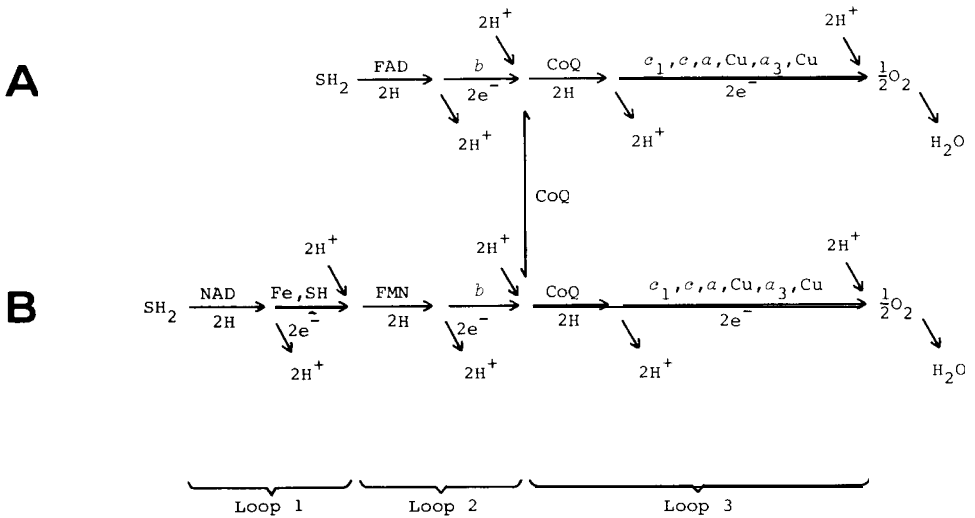

Fig. 14. Suggested alternation of H and e- conductors in respiratory chain systems: A, for FAD-linked oxidations; B, for NAD-linked oxidations (after Mitchell, 1966).

As indicated in Fig. 14, the chemiosmotic hypothesis, at the biochemical level, permitted a return to David Keilin's notion of a chemically simple respiratory chain; but the protonmotive property would have to depend on a topological complexity in place of the chemical complexity favoured by the proponents of the chemical coupling type of hypothesis. This seemed to me to be an attractive notion because it was in accord with the evidence of the need for a special topological organisation of the components of the respiratory chain, as shown by David Keilin's early work on the reversible dissociability of cytochrome c, and by the important pioneering work of Keilin & King (see King, 1966) on the reversible dissociation of succinate dehydrogenase from the succinate oxidase complex of mitochondria - which, as we now know, set the scene for later topological resolution and reconstitution studies.

Fig. 15 shows how the alternation of hydrogen and electron carriers down the chain might translocate protons across the membrane, the chain being effectively looped across the osmotic barrier, forming three protonmotive redox loops that I called Loops 1, 2 and 3, corresponding to the three energy-transducing regions of the classical respiratory chain between NADH and oxygen (Mitchell, 1966). In this way, each loop would translocate two protons per bivalent reducing equivalent passing along - giving 6 in all for NADH oxidation, as observed experimentally (see: Mitchell, 1972a, 1976a, 1977b, 1979; Moyle & Mitchell, 1977, 1978a, b).

At equilibrium, the total protonmotive potential across the membrane would be equal to the total redox potential across each loop - that is, around 250 mV (Mitchell, 1966). Thus, we can relate quantitatively the

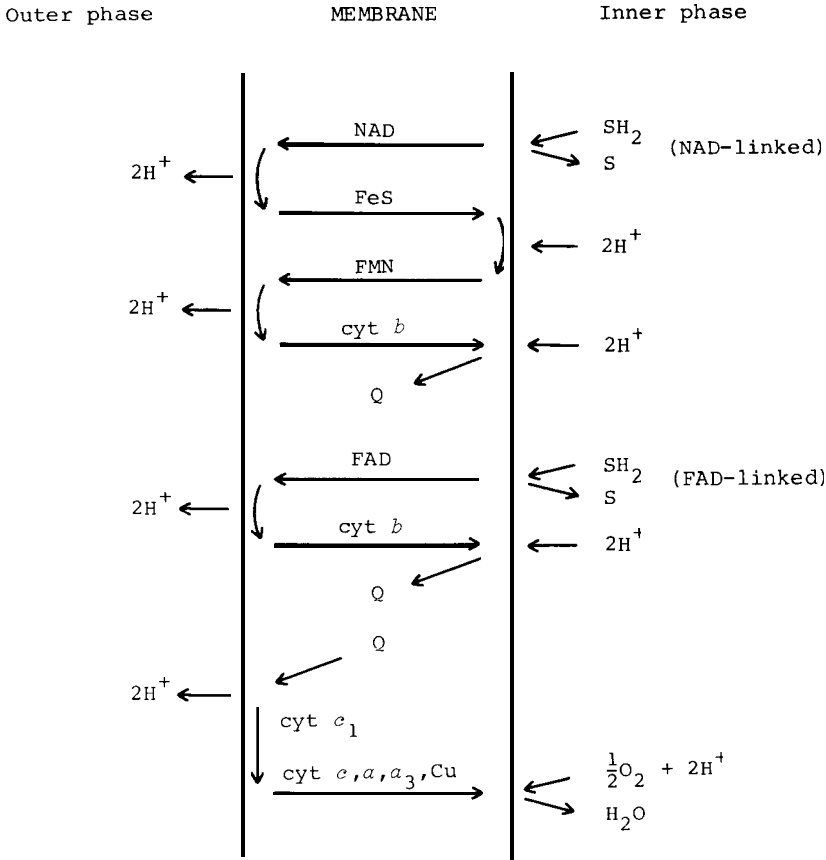

Fig. 15. Suggested looped configuration of respiratory chain systems (after Mitchell, 1966).

scalar group-potential differences of chemical reactions (i.e. of hydrogen and electron transfer reactions) to the real vectorial forces of transport (i.e. of oppositely directed H and e transport, adding up to net H⁺ translocation).

Fig. 16 illustrates my original guesses, (A) for the non-cyclic photoredox chain of chloroplasts, and (B) for the cyclic photoredox chain of certain photosynthetic bacteria, which employ the same direct group-conducting redox-loop principle as that applied to the respiratory chain (Mitchell, 1966). But a subtle difference of behaviour was expected because the orientation of the photosynthetic pigment systems, as represented in these diagrams, should cause a non-thermodynamic photoelectric effect across the membrane with a very short rise-time - as shown by Witt (1967) in elegant experiments on chloroplast thylakoids, and confirmed by Crofts and others in both chloroplasts and photosynthetic bacteria (see Junge, 1977; Witt, 1977; Hall et al., eds, 1978).

A great deal of ingenious experimental work in many laboratories over the last decade has shown that these schemes require some modification of detail, but their direct group-conducting redox-loop principle has been amply confirmed, as indicated in the diagrams of Fig. 17, which, as I shall

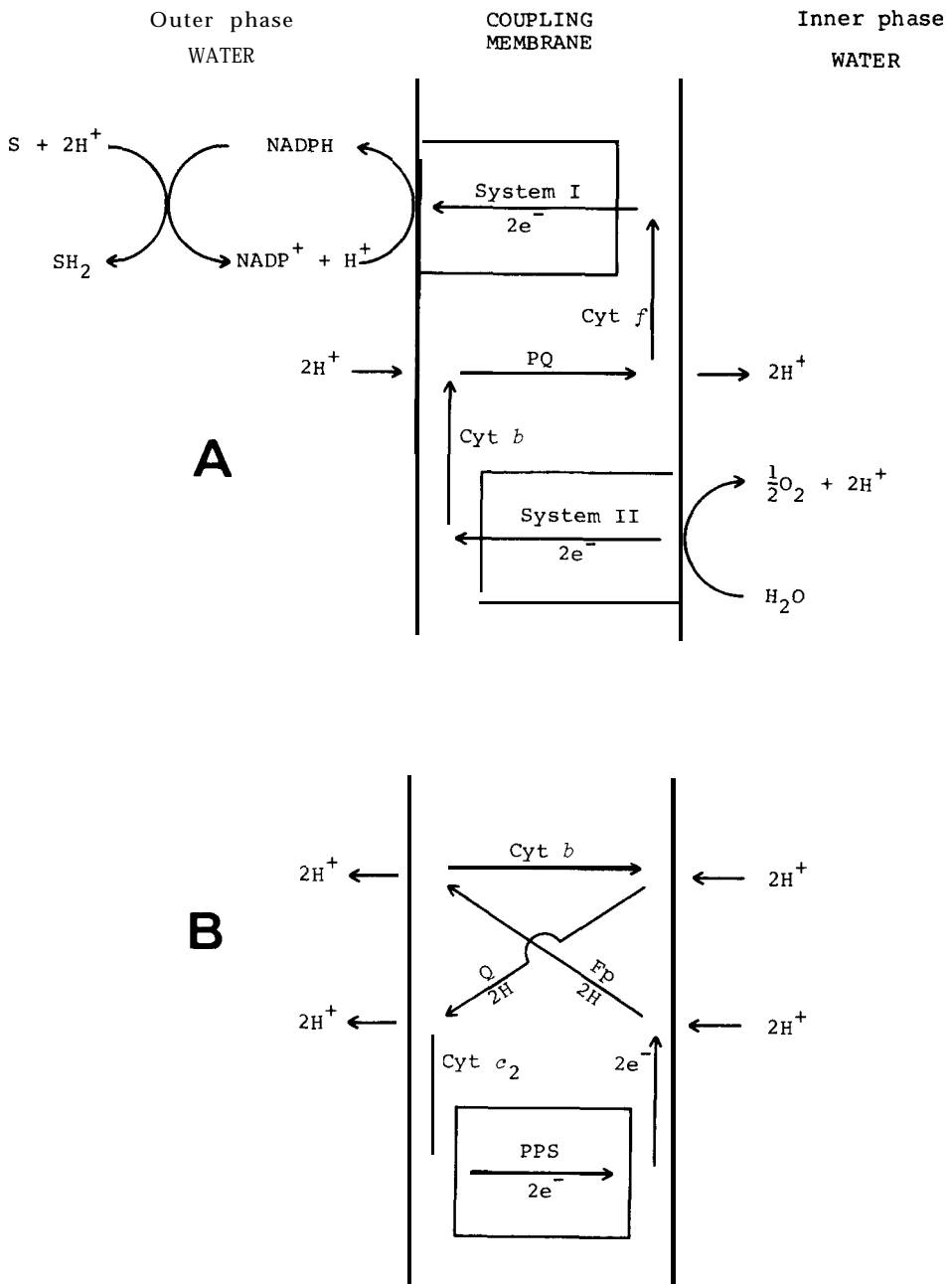

Fig. 16. Suggested protonmotive photoredox chain systems: A, for chloroplast non-cyclic photoredox activity; B, for bacterial cyclic photoredox activity. System I, System II and PPS stand for photosynthetic pigment systems (after Mitchell, 1966, 1967a).

discuss in a little more detail later, summarise recent knowledge about the mitochondrial respiratory chain (A), the chloroplast non-cyclic photoredox chain (B), and the reversible ATPases (F_0F_1 and CF_0CF_1), driven by these systems. It is noteworthy that these schemes show remarkable similarities.

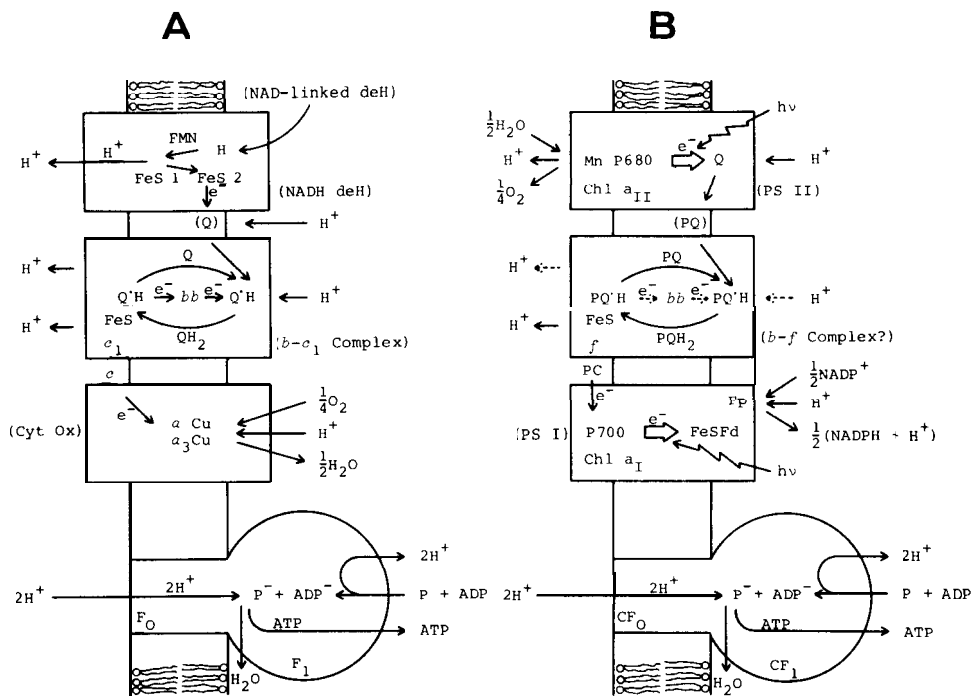

Fig. 17. Direct chemiosmotic mechanisms for: A, mitochondrial oxidative phosphorylation; B, chloroplast non-cyclic photosynthetic phosphorylation: Biochemical level chemiosmotic concept. Research information from many sources (see Dutton et al., eds., 1978; Hall et al., eds., 1978; Mitchell, 1977a, 1979; Trumpower, 1979). Symbols as conventionally used in references cited; and see text.

The photoredox chain system, shown in Fig. 17 B and Fig. 5 B, obviously has a real Z configuration that corresponds to the abstract Z scheme introduced by Hill & Bendall in 1960.

It may well be remarked that the protonmotive stoichiometries of these schemes, which correspond to one proton per univalent reducing equivalent traversing each effective redox loop, represent a crucial datum. In my laboratory, and in most other laboratories where such stoichiometric measurements have been made (see Mitchell, 1979), the $\leftarrow H^+/e^-$ ratio has been found to be near unity per effective redox loop. For reasons discussed elsewhere (Mitchell, 1972a, 1976a, 1977b, 1979; Moyle & Mitchell, 1977, 1978a, b; Jones et al., 1978), I do not think that recent dissent from the laboratories of Azzone (Azzone et al., 1977), Lehninger (Reynafarje & Lehninger, 1978) and Wikstrom (Wikstrom & Krab, 1978) constitutes a serious threat to this relatively hard experimental datum.

We seem, therefore, to have a partial answer to the questions: What is it; how does it do it? It is a system of specific hydrogen and electron conductors, which generates proticity by virtue of the fact that it is effectively looped across the coupling membrane, and catalyses the spontaneous

diffusion of hydrogen atoms and electrons in opposite directions, adding up to net proton translocation across the coupling membrane.

2. A LONG PHYSICOCHEMICAL VIEW OF CHEMICOMOTIVE SYSTEMS

The first protonmotive device conceived by man was the electromotive hydrogen-burning fuel cell, invented by the remarkable William Grove in 1839. It is, perhaps, not self evident that such a fuel cell for generating electricity is also, potentially, a generator of proticity. This is illustrated by the diagrams of the hydrogen-burning fuel cell shown in Fig. 18. It simply depends where one opens the circuit to conduct away the power for external use. In A, the circuit is opened in the electron conductor to give electricity. In B, the circuit is opened in the proton conductor to give proticity (Mitchell, 1967a).

The fuel cell is a beautiful example of the truth of the principle, enunciated by Pierre Curie at the end of the last century (Curie, 1894), that effects cannot be less symmetric than their causes. The phenomena of transport in the fuel cell arise from the intrinsically vectorial disposition of the chemical reactions at the anisotropic metal/aqueous catalytic electrode interfaces (Liebhafsky & Cairns, 1968). Thus, the scalar group-potential differences of the chemical reactions are projected in space as vectorial chemical fields of force corresponding to the chemical group-potential gradients directed across the electrode interfaces. These simple considerations illustrate nicely the nonsensical character of the question asked by certain theoreticians in the context of the coupling between transport and metabolism around 1960, and still persisting in some circles: how can scalar chemical reactions drive vectorial transport processes? The answer is plainly: they can't (Mitchell, 1962, 1967b).

The idea of electrochemical cells and circuits was generalised by Guggenheim in 1933 to include the chemically motivated transport of any two species of chemical particle around a suitably conducting circuit. Guggenheim's rather abstract thermodynamic treatment effectively showed that chemical transport can be coupled reversibly to chemical transformation by splitting the chemical reaction spatially into two half reactions, connected internally by a specific conductor of one chemical species, and connected externally by a specific conductor of another chemical species needed to complete the overall reaction (see Mitchell, 1968). When we include the leading in and out of the reactants and resultants, as in the fuel cell of Fig. 18, we see that there have to be two internal specific ligand conductors arranged in a looped configuration between the interfaces where the chemical half reactions occur (Mitchell, 1967a). Obviously, the external specific ligand conduction process - for example, the flow of protons in Fig. 18 B - must be the sum of the internal specific ligand conduction processes - for example the flow of hydrogen atoms one way and of electrons the opposite way in Fig. 18 B.

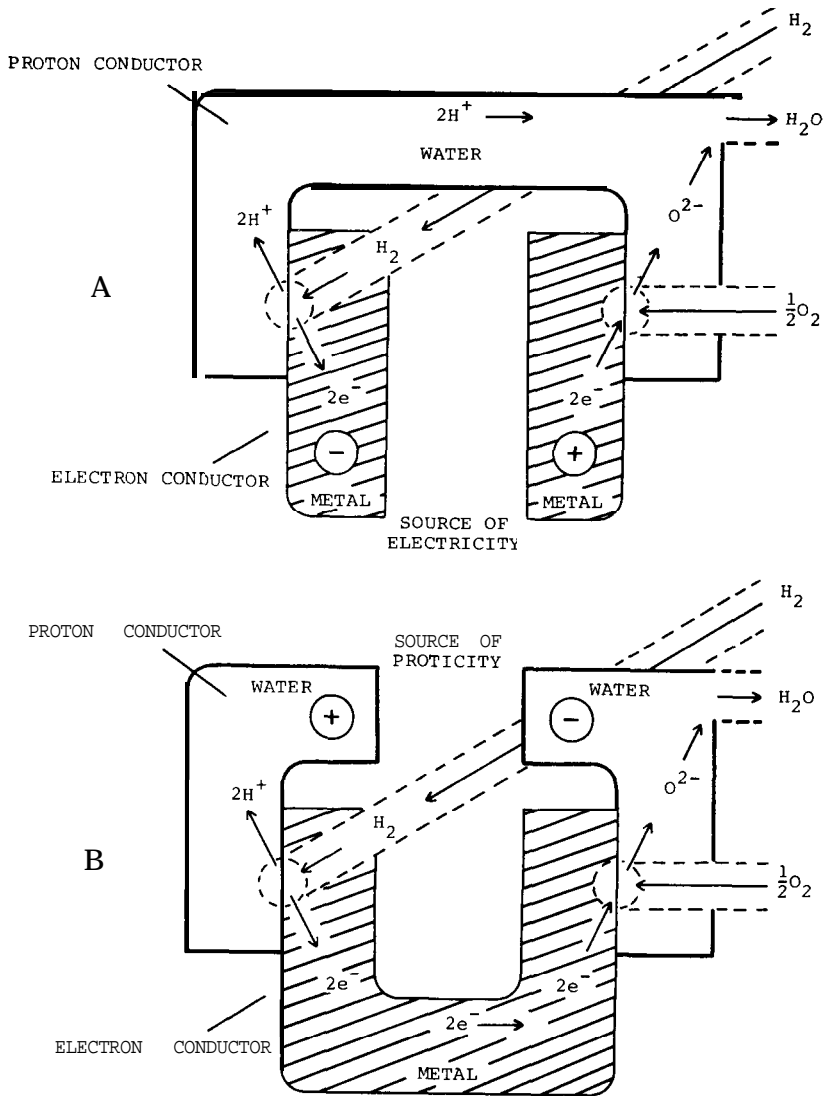
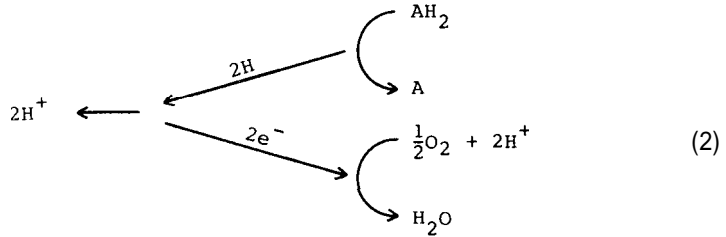

Fig. 18. Hydrogen-burning fuel cell: A, generating electricity; B, generating proticity (after Mitchell, 1967a).

The specification of chemical group conduction in an enzyme or catalytic carrier complex may usefully be considered to correspond to the specification of an internal ligand conduction reaction of a chemicomotive cell, the other internal and external circuit components of which may be determined by the topological arrangement of the specific group-conducting complex, relative to other osmotic or diffusion-regulating systems. Thus, as the name chemiosmotic implies, the intrinsic osmotic property of a

chemical group-translocation or group-conduction reaction in biology represents its chemicomotive potentiality, which may be exploited (through natural selection) by appropriate topological organisation.

For example, the notion of the protonmotive redox loop is based on this type of development of the specific ligand-conducting group-translocation concept



As indicated in equation (2), the internal (trans osmotic barrier) ligand conductors in the redox-loop complex are conceived as being specific for hydrogen atoms that diffuse down their potential gradient one way, and for electrons that diffuse down their (electrochemical) potential gradient the opposite way - exactly as in the fuel cell of Fig. 18 B, and as illustrated further in Fig. 19. The outer circuit consists of the aqueous proton conductors on either side of the insulating lipid membrane (Mitchell, 1966).

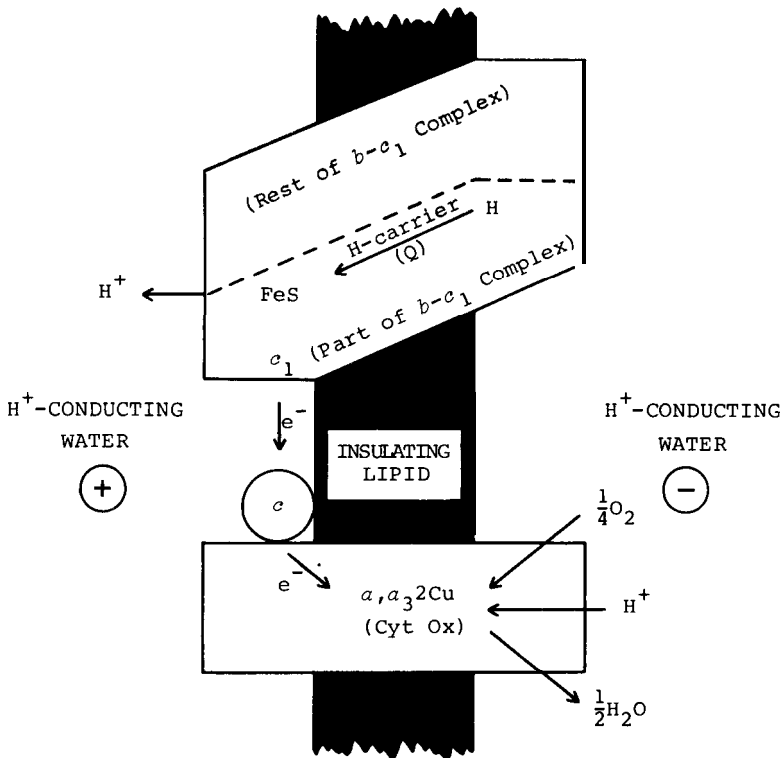
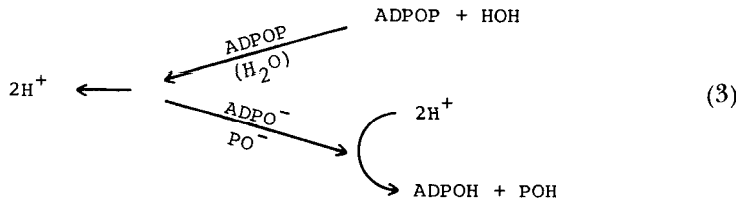

Fig. 19. Fuel cell-like terminal redox loop of respiratory chain (after Mitchell, 1967a).

The notion of the protonmotive hydrodehydration loop for reversible ATP hydrolysis depends on a similar principle (Mitchell, 1966).



As illustrated formally in equation (3), protonmotive ATP hydrolysis may be conceived as the specific conduction of ATP (written ADPOP) and H_2O one way, and of $\text{ADPO}^- + \text{PO}^-$ the opposite way, giving, by difference, the net translocation of 2H^+ . In equation (3) the H_2O is bracketed to denote that there need be no specific H_2O conduction pathway, because lipid membranes generally have a high conductance to water (see Mitchell, 1977a).

The considerations of this section of my lecture look two ways. They show that the chemiosmotic rationale has its roots in physical and chemical theory going back more than a century. They also suggest that the general concept of specific vectorial ligand conduction has very powerful applications in physics, chemistry and biology, which are, as yet, by no means fully appreciated (Mitchell, 1977c).

The protonmotive redox loop and hydrodehydration loop, and other possible chemicomotive loops, as generally defined here, depend on a very simple specific ligand-conduction mechanism. I have called it the direct chemiosmotic mechanism in the biological systems, where it represents a spatial extension of the conventional biochemical concept of group transfer, but it is identical in general principle to the mechanism of man-made fuel cells. I find it remarkably paradoxical, therefore, that many physiologists and biochemists have tended to reject, or have found it difficult to accept intuitively, the feasibility of this direct and most biochemically conventional type of chemiosmotic mechanism (see Boyer, 1974; Skulachev, 1974; Boyer et al., 1977; DePierre & Ernster, 1977; Ernster, 1977a; Papa et al., 1978). Instead, as illustrated in Fig. 20, they have been inclined to adopt exclusively conformationally coupled mechanisms, in which the chemical and osmotic reaction centres are conceived as being separate in space-time, and interact exclusively via the conformational movements of an intervening polypeptide system, indicated by the squiggly line. Such essentially black-box mechanisms involving hypothetical translocators (T), unlike their direct counterparts, can be adjusted to have any stoichiometry (n) to suit the experiments of the day, and they are of such low information-content biochemically as to be very difficult to disprove experimentally. By providing a blanket explanation, but without currently testable detail, it seems to me that the concept of exclusively conformational coupling in chemiosmotic reactions, which can be partly attributed to a spillover from studies of the Na^+/K^+ -motive and Ca^{2+} -motive ATPases,

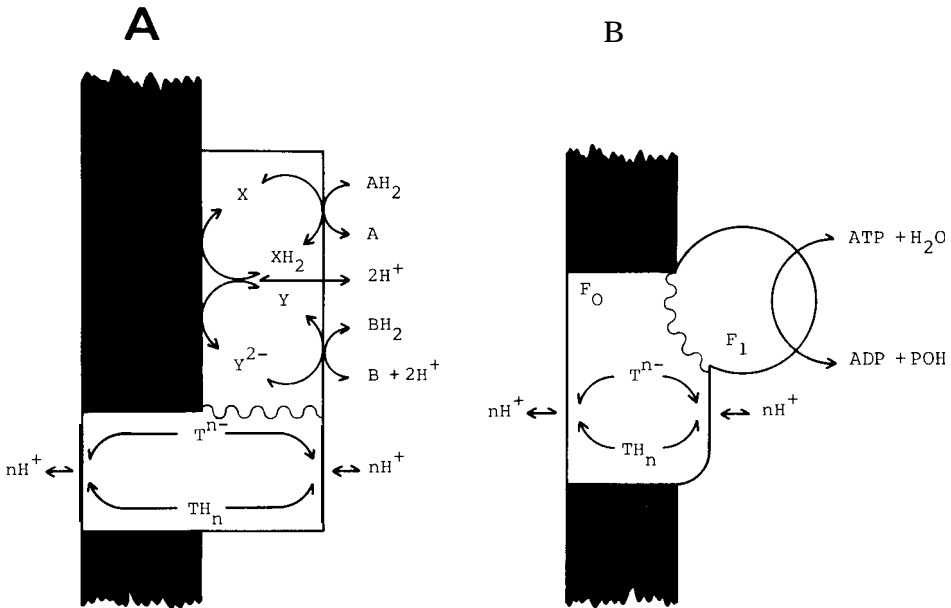

Fig. 20. Completely indirect or exclusively conformational type of chemiosmotic coupling concept: A. for redox proton pump; B. for ATPase proton pump (following Bayer, Chance, Ernster, Skulachev and others. See Mitchell, 1977a).

may actually inhibit productive research by acting as a palliative (see Mitchell, 1977a,c,1979). Conjectures about direct biochemically explicit chemiosmotic mechanisms, on the other hand, even if wrong, promote experimental activity and enthusiasm by suggesting crucial experiments for testing them. This, I think, has been an important strategic function of the biochemical conceptual aspect of the chemiosmotic theory in the recent past, and I would like to persuade more of my colleagues to make use of that function in the future - even, perhaps, in the field of the Na⁺/K⁺-motive and Ca²⁺-motive ATPases (Mitchell, 1973c, 1979) where progress in understanding the general chemiosmotic principle of the mechanisms has so far been rather slow. The fact that the metal ions are not involved directly in stable covalent compounds does not militate against them being involved in stable electrostatic complexes with anionic phosphate groups that move along specific pathways down their group-potential gradients during ATP hydrolysis in the relatively non-aqueous environment of the enzyme active site domain.

Let me interject here that the protonic chemiosmotic theory has a much broader range of applicability than is encompassed by the central field of energy transduction in the classical oxidative and photosynthetic phosphorylation systems, treated in this lecture (see Mitchell, 1976a). For example: there is the protonmotive bacteriorhodopsin system of *Halobacterium halobium* (Stoeckenius, 1977; Schreckenbach & Oesterhelt, 1978;

Drachev et al., 1978; Schulten & Tavan, 1978); the protonmotive pyrophosphatase of photosynthetic bacteria (Moyle et al., 1972); protic heating in fat cell mitochondria of hibernating animals (Heaton et al., 1978); the remarkable rotatory flagellar motor of bacteria, which is driven by proticity (see Manson et al., 1977; Matsuura et al., 1977; Glagolev & Skulachev, 1978); the protonmotive ATPase and proton-coupled porter systems in chloroplast envelope membranes (Heldt, 1976; Edwards & Huber, 1978), in the plasma membranes of moulds, yeasts and higher plants (see Mitchell, 1970b, 1976a; Seaston et al., 1976; Bowman et al., 1978; Delhez et al., 1978), and also in the membranes of chromaffin granules (Njus & Radda, 1978) and synaptosomes (Toll & Howard, 1978); interesting and unusual redox chain systems, such as that of the acidophile *Thiobacillusferro-oxidans* (Ingledeu et al., 1977), which has incidentally helped to rule out the localised protonic anhydride coupling hypothesis; and probably other proticity producing and consuming systems yet to be discovered. Moreover, it was never my wish or intention that the concepts of specific ligand conduction and chemical group translocation (Mitchell, 1956, 1957, 1961a, 1962, 1963), on which the chemiosmotic theory is based, should be confined to systems coupled by proticity. It is only the unique versatility of the uses of proticity (Mitchell, 1976a), and its importance for power transmission in the main pathways of energy metabolism, that has accidentally tended to associate the use of the chemiosmotic theory with protonmotive and protonmotivated systems, rather than with other chemicomotive and chemicomotivated systems. In recent reviews (Mitchell, 1977c, 1979), I have endeavoured to encourage the wider use of chemiosmotic theory, and the powerful biochemical concept of specific ligand conduction, in terms of the general idea of chemicalicity - an explicit extension of Lipmann's marvellously precocious idea of metabolic process patterns (Lipmann, 1946).

3. SOME QUESTIONS OF BIOCHEMICAL DETAIL IN THE PROTONMOTIVE RESPIRATORY CHAIN AND PHOTOREDOX CHAIN

The respiratory chain system summarised in Fig. 17A differs from my earlier suggestion of three linearly arranged redox loops (Figs. 14 and 15) in that loops 2 and 3 are coalesced into a cyclic Loop 2 + 3 configuration, described as the Q cycle, catalysed by the cytochrome b_c complex. In this way, many of the otherwise anomalous thermodynamic poisoning and kinetic characteristics of cytochromes b_{566} and b_{562} (represented by bb in the diagram) may be explained; and the presence of ubiquinone (Q) as the only hydrogen carrier in this redox region, and the site of action of the inhibitor antimycin, may also be rationalised (Mitchell, 1975, 1976b; Rich & Moore, 1976; Rieske, 1976; Trumpower, 1976, 1979; Konstantinov & Ruuge, 1977; King, 1978; Moore, 1978; Rich & Bonner, 1978; Yu et al., 1978; Ragan & Heron, 1978; Heron et al., 1978). As indicated by the broken symbols of Fig. 17B, it is not yet certain whether a similar plasto-

quinone (PQ) cycle may operate in chloroplasts (see Bendall, 1977). Another significant feature of the diagrams of Fig. 17 is the inclusion of iron-sulphur centres (FeS), which, following the beautiful pioneer work of Helmut Beinert, are now thought to have as important a role in electron transport as the haem nuclei of cytochromes (Sands & Beinert, 1960; Beinert, 1977).

The representation of the respiratory and photoredox chains as a set of physically compact complexes (that may be partially resolved and reconstituted) stems from work by Keilin & King (1958), by Takemori & King (1962), by the Madison group, led by Green and Hatefi (see Hatefi 1966), and by Efraim Racker's group (see Racker, 1976). They originally defined four complexes: NADH-Q reductase, succinate-Q reductase, QH₂-cytochrome *c* reductase (the cytochrome ***b-c***, complex) and cytochrome oxidase-functionally linked by ubiquinone and cytochrome *c*. Racker's group added the F₀F₁ and CF₀CF₁ complexes, which are physically and chemically separate from the redox complexes (Racker, 1976, 1977; Jagendorf, 1977; Kozlov & Skulachev, 1977; Kagawa, 1978; Senior, 1979).

The lipid coupling membrane through which the redox and ATPase complexes are plugged is now considered to be very mobile laterally (see Hackenbrock & Höchli, 1977; King, 1978; Heron et al., 1978), in accordance with the fluid membrane concept of Singer & Nicholson (1971).

There are about equal numbers of cytochrome *b-c*₁ and cytochrome oxidase complexes in mitochondrial respiratory chains. Counting all the different Q-linked dehydrogenases (NADH dehydrogenase, succinate dehydrogenase, electron transfer flavoprotein dehydrogenase, choline dehydrogenase, glycerol-1-phosphate dehydrogenase, etc.), there are about as many dehydrogenase complexes as there are cytochrome *b-c*₁ complexes. Thus, there is no special significance of the number four in the redox complexes of Green's group. There is, however, a special significance of two complexes: the cytochrome *b-c*₁ complex and the cytochrome oxidase complex, which are functionally linked by cytochrome *c*, and make up the protonmotive cytochrome system. This remarkably compact system serves all the Q-linked dehydrogenases, only one of which, the NADH dehydrogenase, is, so far, known to be protonmotive itself (Ragan, 1976).

There are generally at least ten Q molecules per cytochrome *b-c*₁ complex, so providing for the redox pool function of Q, identified by Kroger & Klingenberg (1973). However, recent work by Ragan and colleagues (Ragan & Heron, 1978; Heron et al., 1978) on functional interaction between NADH-Q reductase and cytochrome *b-c*₁ complexes in liposomal membranes confirms the thesis of King (1966, 1978) that the most active redox-functional units are binary dehydrogenase-cytochrome *b-c*₁ complexes containing bound Q. Thus, it may be that the Q pool function arises more from rapid lateral lipid mobility, giving rise to a dynamic association-dissociation equilibrium of binary dehydrogenase-cytochrome *b-c*₁ complexes with associated Q, than to the lateral diffusion of free Q molecules between dehydrogenase and cytochrome *b-c*₁ complexes.

Hauska (1977a,b) and Lenaz et al. (1977) have argued that Q and PQ are sufficiently mobile across the lipid phase of liposomes to account for the observed rates of conduction of H atoms across mitochondrial and chloroplast coupling membranes by the Q and PQ pools. It seems likely, however, that, in accordance with the ideas of King, and with the concept of the Q cycle (see Mitchell, 1975), the conduction of H atoms across the osmotic barrier may occur preferentially via specific ligand-conducting Q and PQ domains associated with Q-binding or PQ-binding proteins in the cytochrome *b-c₁* (or *b-f?*) complexes, and in the neighbouring dehydrogenase (or PSII?) complexes (Trumpower, 1976,1978,1979; Gutman, 1977; Yu et al., 1977a,b,1978; King, 1978; Ragan & Heron, 1978; Heron et al., 1978; Hauska, 1977b).

The possible conduction of H atoms by flavin mononucleotide (FMN) in NADH dehydrogenase is based only on the known H-binding property of the flavin group (Mitchell, 1972a; Garland et al., 1972; Gutman et al., 1975). The very wide gap between the redox midpoint potentials of FeS1 and FeS2, and the effects of $\Delta\phi$ in poisoning these centres, are difficult to reconcile with the arrangement shown in Fig. 17A (Ohnishi, 1979). As indicated in Fig. 21, I suggest rather speculatively that a protein-bound

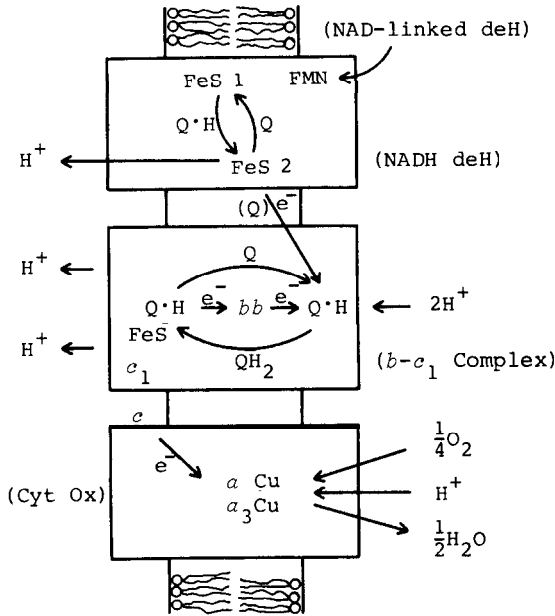

Fig. 2 1. Speculative suggestion for involvement of the Q·H/Q couple in NADH-Q reductase, and connection to cytochrome system.

Q·H/Q couple, acting between FeS1 and FeS2, might possibly account better for the general behaviour of the protonmotive NADH dehydrogenase, and for its requirement (Lenaz et al., 1975) for a specific homologue of Q.

The notion of the net conduction of O^{2-} groups by $(ADP + P)/ATP$ antiport in F_1 and CF_1 (Mitchell, 1972b, 1977a) is based on the precedent of the mitochondrial ADP/ATP antiporter, which is known to conduct ADP and ATP only in specific protonation states (Klingenberg, 1977). The protonmotive $NAD(P)$ transhydrogenase, not shown in Fig. 17, may likewise translocate protons by the effective antiport of the phosphate groups of NAD and $NADP$, in different protonation states determined by the redox states of the nicotinamide groups (Mitchell, 1972b).

In summary, the bioenergetically efficient mechanisms, represented in outline by Fig. 17, depend on two main principles: 1, the semi-fluid bimolecular lipid membrane and the plug-through complexes form a condensed, continuous non-aqueous (protonically insulating) sheet that acts as the osmotic barrier and separates the aqueous proton conductors on either side; 2, components of the complexes plugged through the membrane catalyse the highly specific vectorially organised conduction of electrons, H atoms, H^+ ions and O^{\ominus} groups. As examples of specific ligand *binding*, we have the electron-accepting action of cytochromes or ironsulphur centres, the hydrogen-accepting action of flavoproteins or Q -proteins, and the O^{2-} - accepting action of the $ATP/(ADP + P)$ couple. But the action of specific ligand *conduction* in the plug-through chemiosmotic complexes requires additional dynamic topological, physical and chemical specifications that facilitate the diffusion of the ligands along uniquely articulated pathways down through-space or through-bond fields of force.

There is still much to be understood about the biochemical details of the specific ligand-conduction processes, even for electron conduction (King, 1978; Dockter et al., 1978). But, I think it is fair to say that the protonmotive property of the mitochondrial cytochrome system and the photosystems of chloroplasts can probably be correctly explained, in general principle, by the direct ligand-conduction type of chemiosmotic mechanism. The same may be said of the protonmotive property of the photosystems of bacterial chromatophores (Crofts & Bowyer, 1978; Dutton et al., 1978), and of certain bacterial redox chains (see Hamilton & Haddock, eds, 1977; Jones et al., 1978). The mechanism of the protonmotive $ATPase$ is more controversial; but, at all events, mechanistic conjectures of the direct chemiosmotic type seem to me to be strategically valuable because they stimulate rational experimental research and thereby add to our biochemical knowledge, even if they ultimately turn out to be wrong.

4. CONCLUSION AND PROSPECT

The students of membrane biochemistry and bioenergetics have endured a long period of uncertainty and conceptual upheaval during the last thirty years - a time of great personal, as well as scientific, trauma for many of us.

The present position, in which, with comparatively few dissenters, we have successfully reached a consensus in favour of the chemiosmotic

theory, augurs well for the future congeniality and effectiveness of experimental research in the field of membrane biochemistry and bioenergetics. At the time of the most intensive testing of the chemiosmotic hypothesis, in the nineteensixties and early nineteenseventies, it was not in the power of any of us to predict the outcome. The aspect of the present position of consensus that I find most remarkable and admirable, is the altruism and generosity with which former opponents of the chemiosmotic hypothesis have not only come to accept it, but have actively promoted it to the status of a theory. According to their classically Popperian view (see Mitchell, 1977b), the chemiosmotic theory is worth accepting, for the time being, as the best conceptual framework available (Slater, 1977). Thus to have falsified the pessimistic dictum of the great Max Planck is, I think, a singularly happy achievement.

Returning, finally, to the theme of the respiratory chain, it is especially noteworthy that David Keilin's chemically simple view of the respiratory chain appears now to have been right all along - and he deserves great credit for having been so reluctant to become involved when the energy-rich chemical intermediates began to be so fashionable. This reminds me of the aphorism: "The obscure we see eventually, the completely apparent takes longer".

ACKNOWLEDGEMENTS

I am especially indebted to my research associate, Jennifer Moyle, for constant discussion, criticism and help. Many colleagues have contributed to the evolution of ideas and knowledge traced in this lecture. In particular, I would like to mention the influence of Tsou King, after the premature death of David Keilin in 1963. I would also like to acknowledge that it was Bill Slater who persuaded me to become more deeply involved in practical research on oxidative phosphorylation in 1965, when Jennifer Moyle and I first commenced work at the Glynn Research Laboratories. I thank Jim Danielli for the photograph shown in Fig. 6; I thank Jack Dunitz and Ulrich Müller-Herold for help in researching the dictum of Max Planck (1928, 1933); and I thank Bernie Trumpower and Carol Edwards for informing me, prior to publication of their work, that factor OxF is probably a reconstitutively active form of the Rieske ironsulphur protein, thus influencing the representation of the Q cycle in Fig. 17A. I am grateful to Robert Harper and Stephanie Key for help in preparing the manuscript, and to Glynn Research Ltd for general financial support.

REFERENCES

- Arnon, D. I., Whatley, F. R. and Allen, M. B. (1954) *J. Am. Chem. Soc.* 76, 6324-6328.
- Azzone, G. F., Pozzan, T. and Bragadin, M. (1977) *BBA Library* 14, 107-116.
- Beinert, H. (1977) *BBA Library* 14, 11-21.
- Belitser, V. A. and Tsybakova, E. T. (1939) *Biokhimiya* 4, 516-535.
- Bendall, D. S. (1977) in *Internat. Rev. of Biochem. Plant Biochem. II* (Northcote, D. H., ed.) vol. 13, pp. 41-78, University Park Press, Baltimore.
- Bowman, B. J., Mainzer, S. E., Allen, K. E., and Slayman, C. W. (1978) *Biochim. Biophys. Acta* 512, 13-28.
- Bayer, P. D., Falcone, A. B. and Harrison, W. H. (1954) *Nature* 174, 401-404.
- Boyer, P. D. (1963) *Science* 141, 1147-1153.
- Bayer, P. D. (1965) in *Oxidases and Related Redox Systems* (King, T. E. et al., eds) vol. 2, pp. 994-1008, John Wiley, New York.
- Boyer, P. D., Cross, R. L. and Momsen, W. (1973) *Proc. Nat. Acad. Sci. U.S.A.* 70, 2837-2839.
- Boyer, P. D. (1974) *BBA Library* 13, 289-301.
- Boyer, P. D., Chance, B., Ernster, L., Mitchell, P., Racker, E. and Slater, E. C. (1977) *Ann. Rev. Biochem.* 46, 955-1026.
- Chance, B. and Williams, G. R. (1956) *Adv. Enzymol.* 27, 65-134.
- Chance, B. (1961) *J. Biol. Chem.* 236, 1569-1576.
- Chance, B., Lee, C. P. and Mela, L. (1967) *Fed. Proc.* 26, 1341-1354.
- Chance, B. (1972) *FEBS Lett.* 23, 3-20.
- Chance, B. (1974) *Ann. N.Y. Acad. Sci.* 227, 613-626.
- Chappell, J. B. (1968) *Brit. Med. Bull.* 24, 150-157.
- Conway, E. J. (1951) *Science* 113, 270-273.
- Crofts, A. R. and Bowyer, J. (1978) in *The Proton and Calcium Pumps* (Azzone, G. F. et al., eds) pp. 55-64, Elsevier/North-Holland, Amsterdam.
- Cross, R. L. and Boyer, P. D. (1973) in *Mechanisms in Bioenergetics* (Azzone, G. F. et al., eds) pp. 149-155, Academic Press, New York.
- Curie, P. (1894) *J. Phys.*, 3ème Ser. 393-415.
- Davies, R. E. and Ogston, A. G. (1950) *Biochem. J.* 46, 324-333.
- Delhez, J., Dufour, J.-P., Thines, D. and Goffeau, A. (1977) *Eur. J. Biochem.* 79, 319-328.
- DePierre, J. W. and Ernster, L. (1977) *Ann. Rev. Biochem.* 46, 201-262.
- Dockter, M. E., Steinmann, A. and Schatz, G. (1978) *J. Biol. Chem.* 253, 311-317.
- Drachev, L. A., Kaulen, A. D. and Skulachev, V. P. (1978) *FEBS Lett.* 87, 161-167.
- Dutton, P. L., Bashford, C. L., van den Bergh, W. H., Banner, H. S., Chance, B., Jackson, J. B., Petty, K. M., Prince, R. C., Sorge, J. R. and Takamiya, K. (1978) in *Photosynthesis 77, Proc. Fourth Internat. Congr. Photosynth.* (Hall, D. O. et al., eds) pp. 159-171, Biochem. Soc., London.
- Dutton, L., Leigh, J. and Scarpa, A., eds (1978) *Frontiers of Biological Energetics*, Academic Press, New York.
- Ewards, G. E. and Huber, S. C. (1978) in *Photosynthesis 77, Proc. Fourth Internat. Congr. Photosynth.* (Hall, D. O. et al., eds) pp. 95-106, Biochem. Soc., London.
- Ernster, L. and Lee, C. P. (1964) *Ann. Rev. Biochem.* 33, 729-788.
- Ernster, L., Juntti, K. and Asami, K. (1973) *J. Bioenerg.* 4, 149-159.
- Ernster, L., Nordenbrand, K., Chude, O. and Juntti, K. (1974) in *Membrane Proteins in Transport and Phosphorylation* (Azzone, G. F. et al., eds) pp. 29-41, North-Holland, Amsterdam.
- Ernster, L. (1977a) in *Living Systems as Energy Converters* (Buvet, R. et al., eds) pp. 115-118, North-Holland, Amsterdam.
- Ernster, L. (1977b) in *Bioenergetics of Membranes* (Packer, L. et al., eds) pp. 373-376, Elsevier/North-Holland, Amsterdam.
- Friedkin, M. and Lehninger, A. L. (1948) *J. Biol. Chem.* 174, 757-758.

- Garland, P. B., Clegg, R. A., Downie, J. A., Gray, T. A., Lawford, H. G. and Skyrme, J. (1972) FEBS Symp. 28, 105-117.
- Glagolev, A. N. and Skulachev, V. P. (1978) Nature 272, 280-282.
- Green, D. E., Beyer, R. E., Hansen, M., Smith, A. L. and Webster, G. (1963) Fed. Proc. 22, 1460-1468.
- Green, D. E. (1974) Biochim. Biophys. Acta 346, 27-78.
- Griffiths, D. E. (1965) in *Essays in Biochemistry* (Campbell, P. N. and Greville, G. D., eds) vol. 1, pp. 91-120, Academic Press, London.
- Griffiths, D. E., Hyams, R. L. and Bertoli, E. (1977) FEBS Lett. 74, 38-42.
- Grove, W. R. (1839) Phil. Mag., Ser. 3, 14, 127-130.
- Guggenheim, E. A. (1933) *Modern Thermodynamics by the Methods of Willard Gibbs*, Methuen, London.
- Gutman, M., Beinert, H. and Singer, T. P. (1975) in *Electron Transfer Chains and Oxidative Phosphorylation* (Quagliariello, E. et al., eds) pp. 55-62, North-Holland, Amsterdam.
- Gutman, M. (1977) in *Bioenergetics of Membranes* (Packer, L. et al., eds) pp. 165-175, Elsevier/North-Holland, Amsterdam.
- Hackenbrock, C. R. and Höchli, M. (1977) FEBS Symp. 42, 10-36.
- Hall, D. O., Coombs, J. and Goodwin, T. W., eds (1978) *Photosynthesis 77, Proc. Fourth Internat. Congr. Photosynth.*, Biochem. Soc., London.
- Hamilton, W. A. and Haddock, B. A., eds (1977) Symp. Soc. Gen. Microbiol. 27.
- Harold, F. M. (1977a) Curr. Top. Bioenerg. 6, 83-149.
- Harold, F. M. (1977b) Ann. Rev. Microbiol. 31, 181-203.
- Hatefi, Y. (1963) Adv. Enzymol. 25, 275-328.
- Hatefi, Y. (1966) Compr. Biochem. 14, 199-231.
- Hatefi, Y. and Hanstein, W. G. (1972) J. Bioenerg. 3, 129-136.
- Hauska, G. (1977a) in *Bioenergetics of Membranes* (Packer, L. et al., eds) pp. 177-186, Elsevier/North-Holland, Amsterdam.
- Hauska, G. (1977b) in *Photosynthesis 77, Proc. Fourth Internat. Congr. Photosynth.* (Hall, D. O. et al., eds) pp. 185-196, Biochem. Soc., London.
- Heaton, G. M., Wagenvoort, R. J., Kemp, A. and Nicholls, D. G. (1978) Eur. J. Biochem. 82, 515-521.
- Heldt, H. W. (1976) in *The Intact Chloroplast* (Barber, J., ed) pp. 215-234, Elsevier, Amsterdam.
- Heron, C., Ragan, C. I. and Trumppower, B. L. (1978) Biochem. J. 174, 791-800.
- Hill, R. and Bendall, F. (1960) Nature 186, 136-137.
- Hinkle, P. C. and McCarty, R. E. (1978) Scientific American 238, 104-123.
- Ingledeu, W. J., Cox, J. C. and Halling, P. J. (1977) FEBS Microbiology Letters 2, 193-197.
- Jagendorf, A. T. (1967) Fed. Proc. 26, 1361-1369.
- Jagendorf, A. T. (1977) in *Encyclopedia of Plant Physiol. New Series* (Trebst, A. and Avron, M., eds) vol. 5, pp. 307-377, Springer Verlag, Berlin.
- Jones, C. W., Brice, J. M. and Edwards, C. (1978) FEBS Symp. 49, 89-97.
- Junge, W. (1977) Ann. Rev. Plant Physiol. 28, 503-536.
- Junge, W., Auslinder, W., McGeer, A. and Runge, T. (1979a) Biochim. Biophys. Acta, 546, 121-141.
- Junge, W., McGeer, A. J., Auslinder, W. and Kolla, J. (1979b) in *29th Mosbach Colloq.* (Schäfer, G. and Klingenberg, M., eds) in press, Springer Verlag, Berlin.
- Kagawa, Y. (1978) Biochim. Biophys. Acta 505, 45-93.
- Kalckar, H. (1937) Enzymologia 2, 47-52.
- Keilin, D. (1925) Proc. Roy. Soc. B 98, 312-339.
- Keilin, D. (1929) Proc. Roy. Soc. B 104, 206-252.
- Keilin, D. and King, T. E. (1958) Nature 181, 1520-1522.
- King, T. E. (1966) Adv. Enzymol. 28, 155-236.
- King, T. E. (1978) FEBS Symp. 45, 17-31.
- Klingenberg, M. (1977) BBA Library 14, 275-282.
- Konstantinov, A. A. and Ruuge, E. K. (1977) FEBS Lett. 81, 137-141.

- Kozlov, I. A. and Skulachev, V. P. (1977) *Biochim. Biophys. Acta* 463, 29-89.
- Kröger, A. and Klingenberg, M. (1973) *Eur. J. Biochem.* 34, 358-368, and 39, 313-323.
- Kundig, W., Ghosh, S., and Roseman, F. D. (1964) *Proc. Nat. Acad. Sci. U. S. A.* 52, 1067-1074.
- Lardy, H. A., Connelly, J. L. and Johnson, D. (1964) *Biochemistry* 3, 1961- 1968.
- Lehninger, A. L. (1959) *Rev. Modern Physics* 31, 136-146.
- Lehninger, A. L. (1962) *Physiol. Rev.* 42, 467-517.
- Lehninger, A. L. and Wadkins, C. L. (1962) *Ann. Rev. Biochem.* 31, 47-78.
- Lenaz, G., Pasquali, P., Bertoli, E., Parenti-Castelli, G. and Folkers, K. (1975) *Archs. Biochem. Biophys.* 169, 2 17-226.
- Lenaz, G., Mascarello, S., Laudi, L., Cabrini, L., Pasquali, P., Parenti-Castelli, G., Sechi, A. M. and Bertoli, E. (1977) in *Bioenergetics of Membranes* (Packer, L. et al., eds) pp. 189-198, Elsevier/North-Holland, Amsterdam.
- Liebhafsky, H. A. and Cairns, E. J. (1968) *Fuel Cells and Fuel Batteries*, John Wiley, New York.
- Lipmann, F. (1941) *Adv. Enzymol.* I, 99-162.
- Lipmann, F. (1946) in *Currents in Biochemical Research* (Green, D. E., ed.) pp. 137-148, Interscience, New York.
- Lipmann, F. (1960) in *Molecular Biology* (Nachmansohn, D., ed.) pp. 37-47, Academic Press, New York.
- Lundegardh, H. (1945) *Arkiv. Bot.* 32 A 12, 1-139.
- Manson, M. D., Tedesco, P., Berg, H. C., Harold, F. M. and Van der Drift, C. (1977) *Proc. Nat. Acad. Sci. U. S. A.* 74, 3060-3064.
- Matsuura, S., Shioi, J. -i. and Imae, Y. (1977) *FEBS Lett.* 82, 187-190.
- Mitchell, P. (1949) in *The Nature of the Bacterial Surface* (Miles, A. A. and Pirie, N. W., eds) pp. 55-75, Blackwell, Oxford.
- Mitchell, P. (1954) *Symp. Soc. Exp. Biol.* 8, 254-261.
- Mitchell, P. (1956) *Discuss. Farad. Soc.* 21, 278-279 and 282-283.
- Mitchell, P. and Moyle, J. (1956) *Discuss. Farad. Soc.* 21, 258-265.
- Mitchell, P. (1957) *Nature* 180, 134- 136.
- Mitchell, P. and Moyle, J. (1958a) *Nature* 182, 372-373.
- Mitchell, P. and Moyle, J. (1958b) *Proc. Roy. Phys. Soc., Edinburgh* 27, 61-72.
- Mitchell, P. (1959) *Biochem. Soc. Symp.* 16, 73-93.
- Mitchell, P. (1961a) in *Membrane Transport and Metabolism* (Kleinzeller, A. and Kotyk, A., eds) pp. 22-34, Academic Press, New York.
- Mitchell, P. (1961b) in *Biological Structure and Function, Proc. First IUB/IUBS Internat. Symp.*, Stockholm, 1960 (Goodwin, T. W. and Lindberg, O., eds) vol. 2, pp. 581-599, Academic Press, London.
- Mitchell, P. (1961c) *Nature* 191, 144-148.
- Mitchell, P. (1962) *J. Gen. Microbial.* 29, 25-37.
- Mitchell, P. (1963) *Biochem. Soc. Symp.* 22, 142-168.
- Mitchell, P. and Moyle, J. (1965) *Nature* 208, 147-151.
- Mitchell, P. (1966) *Chaismotic Coupling in Oxidative and Photosynthetic Phosphorylation*, Glynn Research, Bodmin, Cornwall, England.
- Mitchell, P. (1967a) *Fed. Proc.* 26, 1335-1340.
- Mitchell, P. (1967b) *Compr. Biochem.* 22, 167-197.
- Mitchell, P. (1967c) *Adv. Enzymol.* 29, 33-85.
- Mitchell, P. and Moyle, J. (1967) *Biochem. J.* 105, 1147-1162.
- Mitchell, P. (1968) *Chaismotic Coupling and Energy Transduction*, Glynn Research, Bodmin, Cornwall, England.
- Mitchell, P. and Moyle, J. (1968) *Eur. J. Biochem.* 4, 530-539.
- Mitchell, P. (1970a) *Membr. Ion Transp.* I, 192-256.
- Mitchell, P. (1970b) *Symp. Sot. Gen. Microbial.* 20, 121-166.
- Mitchell, P. (1972a) *FEBS Symp.* 28, 353-370.
- Mitchell, P. (1972b) *J. Bioenerg.* 3, 5-24.
- Mitchell, P. (1973a) *J. Bioenerg.* 4, 63-91.

- Mitchell, P. (1973b) in *Mechanisms in Bioenergetics* (Azzone, G. F. et al., eds) pp. 177-201, Academic Press, New York.
- Mitchell, P. (1973c) FEBS Lett. 33, 267-274.
- Mitchell, P. (1975) in *Electron Transfer Chains and Oxidative Phosphorylation* (Quagliariello, E. et al., eds) pp. 305-316, North-Holland, Amsterdam.
- Mitchell, P. (1976a) Biochem. Soc. Trans. 4, 399-430.
- Mitchell, P. (1976b) J. Theoret. Biol. 62, 327-367.
- Mitchell, P. (1977a) FEBS Lett. 78, 1-20.
- Mitchell, P. (1977b) Ann. Rev. Biochem. 46, 996-1005.
- Mitchell, P. (1977c) Symp. Soc. Microbiol. 27, 383-423.
- Mitchell, P. (1979) Eur. J. Biochem. 95, 1-20.
- Moore, A. L. (1978) FEBS Symp. 49, 141-147.
- Moyle, J., Mitchell, R. and Mitchell, P. (1972) FEBS Lett. 23, 233-236.
- Moyle, J. and Mitchell, P. (1977) FEBS Lett. 84, 135-140.
- Moyle, J. and Mitchell, P. (1978a) FEBS Lett. 88, 268-272.
- Moyle, J. and Mitchell, P. (1978b) FEBS Lett. 90, 361-365.
- Nicholls, P. (1963) in *The Enzymes* (Boyer, P. D. et al., eds) vol. 8, part B, pp. 3-40, Academic Press, New York.
- Njus, D. and Radda, G. K. (1978) Biochim. Biophys. Acta 463, 219-244.
- Nordenbrand, K., Hundal, T., Carlsson, C., Sandri, G. and Ernster, L. (1977) in *Bioenergetics of Membranes* (Packer, L. et al., eds) pp 435-446, Elsevier/North-Holland, Amsterdam.
- Ochoa, S. (1940) Nature 146, 267.
- Ohnishi, T. (1979) in *Membrane Proteins in Energy Transduction* (Capaldi, R. A., ed.), 1-87, Marcel Dekker, New York.
- Painter, A. A. and Hunter, F. E. (1970) Biochem. Biophys. Res. Commun. 40, 360-395.
- Papa, S. (1976) Biochim. Biophys. Acta 456, 39-84.
- Papa, S., Guerrieri, F., Lorusso, M., Izzo, G., Boffoli, D. and Stefanelli, R. (1978) FEBS Symp. 45, 37-48.
- Pauling, L. (1950) *Ann. Rep. Smithsonian Inst.* 225-241.
- Planck, M. (1928) *Wissenschaftliche Autobiographie*, Leipzig. Planck's remark, as presented in my paper, is a paraphrase of the following passage on p. 22: "Eine neue wissenschaftliche Wahrheit pflegt sich nicht in der Weise durchzusetzen, dass ihre Gegner überzeugt werden und sich als belehrt erklären, sondern vielmehr dadurch, dass die Gegner allmählich aussterben und dass die heranwachsende Generation von vornherein mit der Wahrheit vertraut gemacht ist." But I have partly followed a later variant of this passage, given in Planck (1933), where he substituted the word *Idee* for *Wahrheit*.
- Planck, M. (1933) *Ursprung und Auswirkung wissenschaftlicher Ideen*. A lecture reproduced in *Planck's Vorträge und Erinnerungen*, Darmstadt, 1975.
- Racker, E. (1961) Adv. Enzymol. 23, 323-399.
- Racker, E. (1965) *Mechanisms in Bioenergetics*, Academic Press, New York.
- Racker, E. (1967) Fed. Proc. 26, 1335-1340.
- Racker, E. (1976) *A New Look at Mechanisms in Bioenergetics*, Academic Press, New York.
- Racker, E. (1977) Ann. Rev. Biochem. 46, 1006-1014.
- Ragan, C. I. (1976) Biochim. Biophys. Acta 456, 249-290.
- Ragan, C. I. and Heron, C. (1978) Biochem. J. 174, 783-790.
- Reynafarje, B. and Lehninger, A. L. (1978) J. Biol. Chem. 253, 6331-6334.
- Rich, P. R. and Moore, A. L. (1976) FEBS Lett. 65, 339-344.
- Rich, P. R. and Bonner, W. D. (1978) FEBS Symp. 49, 149-158.
- Rieske, J. S. (1976) Biochim. Biophys. Acta 456, 195-247.
- Robertson, R. N. and Wilkins, M. J. (1948) Aust. J. Sci. Res. 1, 17-37.
- Robertson, R. N. (1960) Biol. Rev. 35, 23 1-264.
- Robertson, R. N. (1968) *Protons, Electrons, Phosphorylation and Active Transport*, Cambridge University Press, Cambridge.
- Rosen, B. P. and Kashket, E. R. (1978) in *Bacterial Transport* (Rosen, B. P., ed.) pp. 559-620, Marcel Dekker, New York.

- Rosenberg, T. (1948) *Acta Chem. Scand.* 2, 14-33.
- Sanadi, D. R. (1965) *Ann. Rev. Biochem.* 34, 21-48.
- Sands, R. H. and Beinert, H. (1960) *Biochem. Biophys. Res. Commun.* 3, 47-52.
- Schreckenbach, T. and Oesterhelt, D. (1978) *FEBS Symp.* 45, 105-119.
- Schulten, K. and Tavan, P. (1978) *Nature* 272, 85-86.
- Seaston, A., Carr, G. and Eddy, A. A. (1976) *Biochem. J.* 154, 669-676.
- Senior, A. E. (1979) in *Membrane Proteins in Energy Transduction* (Capaldi, R. A., ed.) in press, Marcel Dekker, New York.
- Singer, S. J. and Nicholson, G. L. (1971) *Science* 175, 720-731.
- Skulachev, V. P. (1970) *FEBS Lett.* 11, 301-308.
- Skulachev, V. P. (1974) *Ann. N. Y. Acad. Sci.* 227, 188-202.
- Skulachev, V. P. (1977) *FEBS Lett.* 74, 1-9.
- Slater, E. C. (1953) *Nature* 172, 975-978.
- Slater, E. C. and Cleland, K. W. (1953) *Biochem. J.* 53, 557-567.
- Slater, E. C. (1958) *Rev. Pure Appl. Chem.* 8, 22 1-264.
- Slater, E. C. and Hulsmann, W. C. (1959) in *Ciba Foundation Symp., Regulation of Cell Metabolism* (Wolstenholme, G. E. W. and O'Connor, C. M., eds) pp. 58-83, Churchill, London.
- Slater, E. C. (1966) *Compr. Biochem.* 14, 327-396.
- Slater, E. C. (1971) *Quart. Rev. Biophys.* 4, 35-71.
- Slater, E. C. (1974) *Biochem. Soc. Trans.* 2, 39-1163.
- Slater, E. C. (1975) in *Electron Transfer Chains and Oxidative Phosphorylation* (Quagliariello, E. et al., eds) pp. 3-14, North-Holland, Amsterdam.
- Slater, E. C. (1976) in *Reflections on Biochemistry* (Kornberg, A. et al., eds) pp. 45-55, Pergamon Press, Oxford.
- Slater, E. C. (1977) in *Living Systems as Energy Converters* (Buvet, R. et al., eds) pp. 221-227, North-Holland, Amsterdam.
- Stoeckenius, W. (1977) *Fed. Proc.* 36, 1797-1798.
- Storey, B. T. (1970) *J. Theoret. Biol.* 28, 233-259.
- Storey, B. T. (1971) *J. Theoret. Biol.* 31, 533-552.
- Takemori, S. and King, T. E. (1962) *Biochim. Biophys. Acta* 64, 192-194.
- Toll, L. and Howard, B. D. (1978) *Biochemistry* 17, 2517-2523.
- Trumpower, B. L. (1976) *Biochem. Biophys. Res. Commun.* 70, 73-80.
- Trumpower, B. L. (1978) *Biochem. Biophys. Res. Commun.* 83, 528-535.
- Trumpower, B. L. and Katki, A. G. (1979) in *Membrane Proteins in Electron Transport* (Capaldi, R. A., ed.) in press, Marcel Dekker, New York.
- Ussing, H. H. (1947) *Nature* 160, 262-263.
- Ussing, H. H. (1949) *Physiol. Rev.* 29, 127-155.
- Wang, J. H. (1972) *J. Bioenerg.* 3, 105-114.
- Weiner, M. W. and Lardy, H. A. (1974) *Archs. Biochem. Biophys.* 162, 568-577.
- Wikström, M. and Krab, K. (1978) *FEBS Lett.* 91, 8-14.
- Williams, R. J. P. (1962) *J. Theoret. Biol.* 3, 209-229.
- Williams, R. J. P. (1970) in *Electron Transport and Energy Conservation* (Tager, J. M. et al., eds) p. 38 1, Adriatica Editrice, Bari.
- Witt, H. T. (1967) in *Fast Reactions and Primary Processes in Chemical Kinetics*, Nobel Symp. 5, (Claesson, S., ed.) pp. 261-316, Interscience, London.
- Witt, H. T. (1977) in *Living Systems as Energy Converters* (Buvet, R. et al., eds) pp. 185-197, Elsevier/North-Holland, Amsterdam.
- Yu, C. A., Yu, L. and King, T. E. (1977a) *Biochem. Biophys. Res. Commun.* 78, 259-265.
- Yu, C. A., Yu, L. and King, T. E. (1977b) *Biochem. Biophys. Res. Commun.* 79, 939-946.
- Yu, C. A., Nagaoka, S., Yu, L. and King, T. E. (1978) *Biochem. Biophys. Res. Commun.* 82, 1070-1078.